



DAL ELEKTRİK
MOTORLARI

**KAPLINLERDE GÜVENİLİR
PERFORMANS**

Reliable Performance in **COUPLINGS**

ENG / TR



**Catch the
world standard in
coupling technologies.**

Kaplin teknolojilerinde
Dünya standardını
yakalayın.



ATEX II 2GD c-T5

REXNORD



DAL ELEKTRİK
MOTORLARI



ATEX II 2GD c T5



ISO 9001:2015



ISO 14001:2015



ISO 45001:2018





KAPLİNLERDE GÜVENİLİR
PERFORMANS

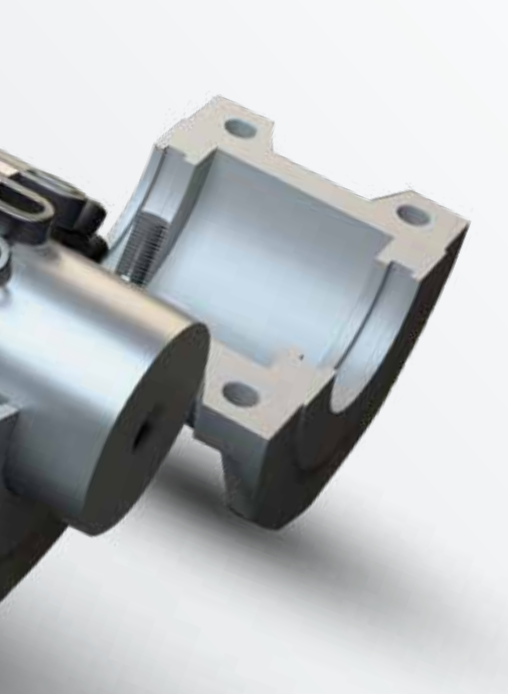
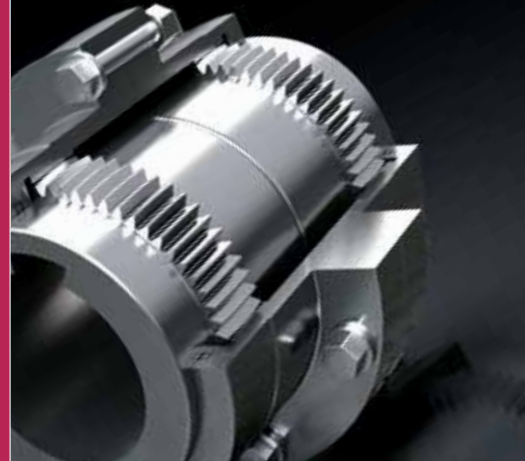

**Reliable Performance in
COUPLINGS**

MODEL	EXPLANATION / AÇIKLAMA	PAGE / SAYFA
VIVA ELASTOMERIC COUPLING ELASTOMERİK KAPLİN	12 Different Sizes Couplings with 62 Nm - 6270 Nm Torque Range 62 Nm - 6270 Nm Tork Aralığında, 12 Farklı Büyüklükte Olan Kaplinler	 04 - 05
VIVA VS ELASTOMERIC COUPLING ELASTOMERİK KAPLİN	Couplings of 12 Different Sizes Used to Provide More Than One Distance Between Shaft Ends By Using Same Elements and Connection Points Between 62 Nm - 6270 Nm Torque Range 62 Nm - 6270 Nm Tork Aralığında Aynı Elemanları ve Bağlantı Noktalarını Kullanarak Şaft Uçları Arasında Birden Fazla Mesafe Sağlamaya Yarayan 12 Farklı Büyüklükte Olan Kaplinler	 06 - 07
OMEGA ELASTOMERIC COUPLING ELASTOMERİK KAPLİN	Couplings with 15 different sizes between 22 Nm - 38400 Nm Torque Range 22 Nm - 38400 Nm Tork Aralığında, 15 farklı Büyüklükte Olan Kaplinler	 08 - 09
OMEGA ES ELASTOMERIC COUPLING ELASTOMERİK KAPLİN	15 Different Sized Couplings to Provide More Than One Distance Between Shaft Ends By Using Same Elements and Connection Points, Between 22 Nm - 38400 Nm Torque Range 22 Nm - 38400 Nm Tork Aralığında, Aynı Elemanları ve Bağlantı Noktalarını Kullanarak Şaft Uçları Arasında Birden Fazla Mesafe Sağlamaya Yarayan 15 Farklı Büyüklükte Olan Kaplinler	 10 - 11
FALK WRAPFLEX ELASTOMERIC COUPLING ELASTOMERİK KAPLİN	Couplings in 9 Different Sizes with 62 Nm - 15000 Nm Torque Range 62 Nm - 15000 Nm Tork Aralığında, 9 Farklı Büyüklükte Olan Kaplinler	 12 - 13
FALK STEELFLEX GRID COUPLING ÇELİK YAYLI KAPLİN	25 Different Sizes of Couplings between 52 Nm - 932000 Nm Torque Range 52 Nm - 932000 Nm Tork Aralığında, 25 Farklı Büyüklükte Olan Kaplinler	 14 - 15
FALK LIFELIGN GEAR COUPLING DİŞLİ KAPLİN	Couplings of 12 Different Sizes in the Torque Range of 1140 Nm - 135000 Nm 1140 Nm - 135000 Nm Tork Aralığında 12 Farklı Büyüklükte Olan Kaplinler	 16 - 17
THOMAS XTSR71 DISC COUPLING DİSK KAPLİN	16 Different Sizes of Couplings with overload peak torque values between 594 Nm - 189000 Nm and continuous torque values between 297 Nm -94300 Nm Aşırı yükleme pik tork değerleri 594 Nm - 189000 Nm aralığında, sürekli tork değerleri ise 297 Nm -94300 Nm aralığında 16 Farklı Büyüklükte Olan Kaplinler	 18 - 19

MODEL
EXPLANATION / AÇIKLAMA
PAGE / SAYFA
THOMAS XTSR52
DISC COUPLING
DİSK KAPLİN

Overload peak torque values in the range of 594 Nm - 189000 Nm, and continuous torque values between 297 Nm -94300 Nm with 16 different sizes of Couplings that can be specially designed according to the request of the customer.

Aşırı yüklemeye pik tork değerleri 594 Nm - 189000 Nm aralığında, sürekli tork değerleri ise 297 Nm -94300 Nm aralığında 16 Farklı Büyüklükte Olan Müşterinin İsteğine Göre Şaft Boyu Özel Dizayn Edilebilecek Kaplinler

20 - 21
THOMAS SR71
DISC COUPLING
DİSK KAPLİN

Overload peak torque values range from 210 Nm to 20704 Nm, and continuous torque values between 105 Nm -10352 Nm with 11 Different Shaft Sizes Designed with Flexible Metallic Disc

Aşırı yüklemeye pik tork değerleri 210 Nm - 20704 Nm aralığında, sürekli tork değerleri ise 105 Nm -10352 Nm aralığında 11 Farklı Büyüklükte Olan Şaftın Esnek Metalik Diskle Dizayn Edildiği Kaplinler

22 - 23
THOMAS SR71-8
DISC COUPLING
DİSK KAPLİN

Overload peak torque values between 3951 Nm - 189388 Nm and continuous torque values in the range of 1976 Nm -94694 Nm 12 Different Sizes of Shafts Designed with Flexible Metallic Disc

Aşırı yüklemeye pik tork değerleri 3951 Nm - 189388 Nm aralığında, sürekli tork değerleri ise 1976 Nm -94694 Nm aralığında 12 Farklı Büyüklükte Olan Şaftın Esnek Metalik Diskle Dizayn Edildiği Kaplinler

24 - 25
THOMAS SR52
DISC COUPLING
DİSK KAPLİN

22 different sizes of couplings with overload peak torque values between 610 Nm - 765 526 Nm and continuous torque values between 305 Nm -382763 Nm

Aşırı yüklemeye pik tork değerleri 610 Nm - 765526 Nm aralığında, sürekli tork değerleri ise 305 Nm -382763 Nm aralığında 22 Farklı Büyüklükte Olan Kaplinler

26 - 27
THOMAS SR54RDG
DISC COUPLING
DİSK KAPLİN

14 different sizes of couplings with overload peak torque values between 610 Nm - 152359 Nm and continuous torque values between 305 Nm -76180 Nm

Aşırı yüklemeye pik tork değerleri 610 Nm - 152359 Nm aralığında, sürekli tork değerleri ise 305 Nm -76180 Nm aralığında 14 Farklı Büyüklükte Olan Kaplinler

28 - 29
THOMAS AMR/CMR
DISC COUPLING
DİSK KAPLİN

Continuous torque values are between 648 Nm -352676 Nm and 22 Different Sizes of Couplings.

Sürekli tork değerleri ise 648 Nm -352676 Nm aralığında 22 Farklı Büyüklükte Olan Kaplinler

30 - 31
ADDAX
COMPOSITE COUPLING
KOMPOZİT KAPLİN

Couplings produced as a composite in 1987 under the leadership of Rexnord Company

Kompozit olarak 1987 yılında ilk defa Rexnord Firması'nın Öncülüğünde Üretilen Kaplinler

32 - 34

REXNORD VIVA

Elastomer Coupling



ATEX II 2GD c T5



VIVA
SERIES

Reliable Performance. Trusted Brands.

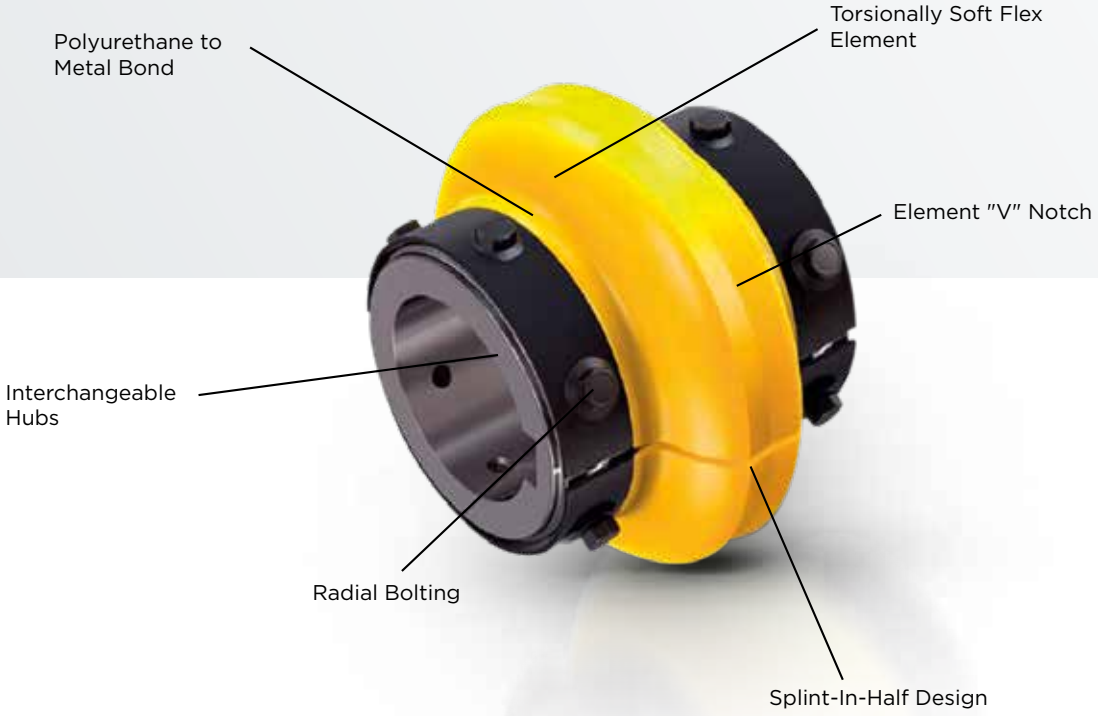

Design Features include:

- Split-in-half flex element design for simplified assembly and disassembly
- Torsionally soft flex element cushions shock loads and vibration, extending equipment life
- Interchangeable hubs allow for reduced inventory
- Polyurethane-to-metal bond eliminates assembly and slippage problems associated with mechanically clamped designs
- Material flexing design allows visual inspection during operation
- Element "V" Notch design provides a uniform failure area for overload protection if required

Tasarım Özellikleri şunları içerir:

- İkiye bölünmüş esnek elemanın montaj ve demontaj kolaylığı
- Eğimli yumuşak elementin ani yüklemeleri ve titreşimleri absorbesi, uzun ömürlülük
- Değiştirilebilir göbekler
- Poliüretan-metal kemiğin mekanik olarak sıkıştırılması ile montaj ve kayma sorunlarını ortadan kaldırması
- Esnek malzeme tasarımı çalışma esnasında görsel incelemeye izin verir.
- "V" Çentik tasarımının aşırı yük esnasında ayrılarak sistem koruması sağlaması eğer gerekliyse

REXNORD VIVA

ELASTOMERİK KAPLINLER

Applications:

- Pumps
- Compressors
- Industrial fans
- Mixers

Industry Compliant:

- ATEX II 2GD c T5

Special design options:

- Rexnord Viva Spline Bore Hub
- Rexnord Viva Positive Drive Coupling
- Rexnord Viva Keyless Hub / Bushing Design
- Limited end float
- Bolt-on brake

Uygulamalar:

- Pompalar
- Kompresörler
- Endüstriyel fanlar
- Mikserler

Endüstri Uyumlu:

- ATEX II 2GD c T5

Özel tasarım seçenekleri:

- Rexnord Viva Oyuklu Hub
- Rexnord Viva Pozitif Hareketli Kaplin
- Rexnord Viva Anahtarsız Hub / Burç Tasarımı
- Sınırlı uç kayma
- Cıvatalı fren

Torque Demands Driven Machine



Typical Application for Electric Motor or Turbine Driven Equipment

Constant torque such as centrifugal pumps blowers and compressors

Typical Service Factor

1.0



Continuous duty with some torque variations including plastic extruders and forced draft fans

1.5



Light shock loads from metal extruders, cooling towers and log haulers

2.0



Moderate shock loading as expected from a car dumper, stone crusher, vibrating screen

2.5



Heavy shock load with some negative torques from reciprocating pumps, compressors, reversing turnout tables

3.0

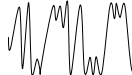

Frequent torque reversals such as reciprocating compressors with frequent torque reversals which do not necessarily include reverse rotations

Consult Rexnord Engineering

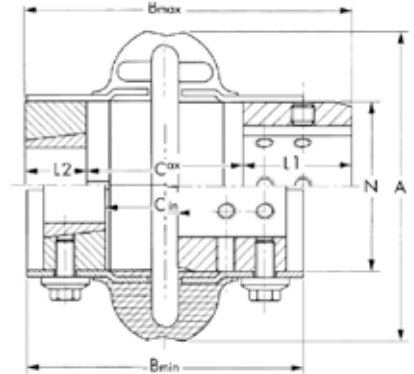

D D2 B B C(1) C(2)

Coupling Size	Tnom	n max	Dmax	Taper	Dmax	A	min.	max.	min.	max.	min.	max.	L1	L2	N	m*	J*
	Nm	min-1	mm	Bush	mm	mm	mm	mm	mm	mm	mm	mm	mm	mm	mm	kg	kgm ²
110	62	5 400	38	1 108	28	110	97	132	9	55	41	55	38	22	60	1,4	0,00123
125	105	5 400	48	1 108	28	125	98	132	9	55	41	55	38	22	70	1,7	0,00202
130	164	5 100	55	1 310	35	130	97	142	7	55	35	55	41	25	80	2,1	0,00310
150	250	4 800	65	1 610	42	150	111	156	9	60	54	66	51	25	95	4,2	0,00900
170	308	4 800	65	1 610	42	170	111	156	9	60	54	66	51	25	95	4,3	0,00931
190	412	4 600	75	2 012	50	190	116	164	7	60	47	60	52	32	114	5,5	0,0173
215	662	4 300	80	2 517	60	215	134	191	11	64	51	61	64	45	140	10	0,0303
245	938	4 100	95	3 020	75	245	137	202	7	73	50	57	65	51	171	14	0,076
290	1 412	3 900	110	3 020	75	290	153	241	8	94	40	87	73	51	215	25	0,192
365	3 200	3 600	127	3 535	90	365	200	311	20	131	20	131	90	90	235	42	0,373
425	5 580	2 000	155	4 040	100	425	247	361	19	133	44	132	114	102	285	85	1,180
460	6 270	2 000	165	4 545	110	460	267	380	19	132	38	132	124	114	302	93	1,720

*weight (m) and inertia (J) with maximum bore and key way • Dimension (C1) finished bore hubs - C(2) with Taper Bush hubs

REXNORD VIVA VS

Elastomer Coupling



ATEX II 2GD c T5



VIVA VS
SERIES

Reliable Performance. Trusted Brands.

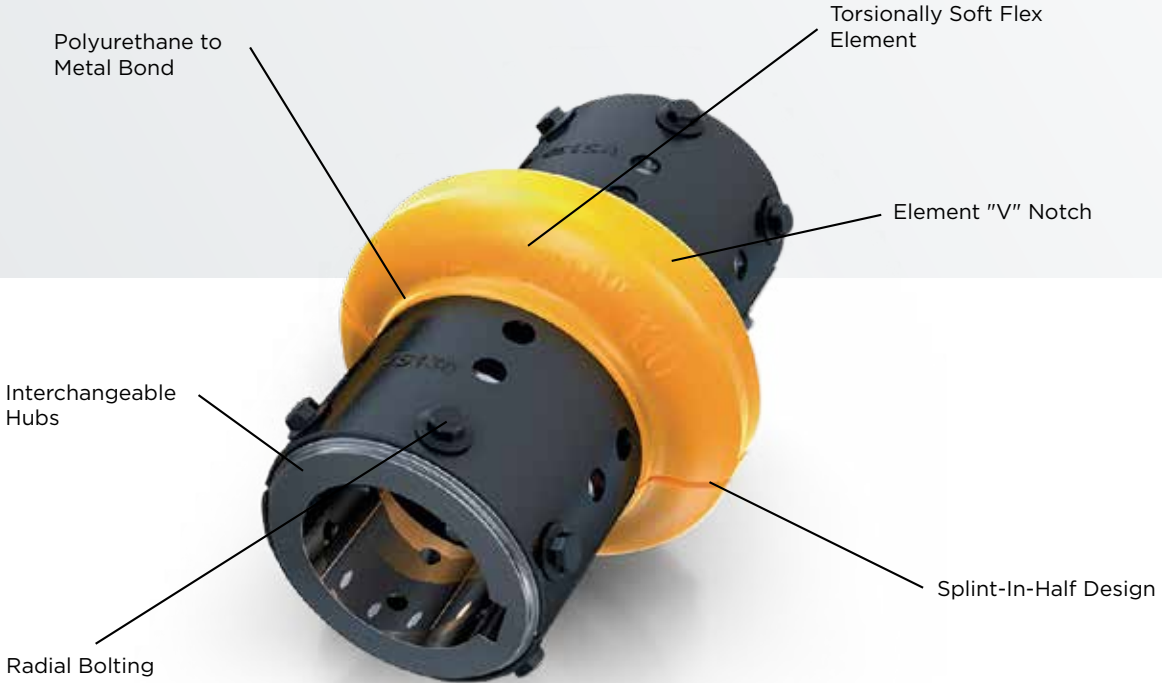

Design Features include:

- Split-in-half flex element design for simplified assembly and disassembly
- Torsionally soft flex element cushions shock loads and vibration, extending equipment life
- Interchangeable hubs allow for reduced inventory
- Polyurethane-to-metal bond eliminates assembly and slippage problems associated with mechanically clamped designs
- Material flexing design allows visual inspection during operation
- Element "V" Notch design provides a uniform failure area for overload protection if required

Tasarım Özellikleri şunları içerir:

- İkiye bölünmüş esnek elemanın montaj ve demontaj kolaylığı
- Eğimli yumuşak elementin ani yüklemeleri ve titreşimleri absorbesi, uzun ömürlülük
- Değiştirilebilir göbekler
- Poliüretan-metal kemiğin mekanik olarak sıkıştırılması ile montaj ve kayma sorunlarını ortadan kaldırması
- Esnek malzeme tasarımı çalışma esnasında görsel incelemeye izin verir.
- "V" Çentik tasarımının aşırı yük esnasında ayrılarak sistem koruması sağlaması eğer gerekliyse

REXNORD VIVA VS ELASTOMERİK KAPLINLER

Applications:

- Pumps
- Compressors
- Industrial fans
- Mixers

Industry Compliant:

- ATEX II 2GD c T5

Special design options:

- Rexnord Viva Spline Bore Hub
- Rexnord Viva Positive Drive Coupling
- Rexnord Viva Keyless Hub / Bushing Design
- Limited end float
- Bolt-on brake

Uygulamalar:

- Pompalar
- Kompresörler
- Endüstriyel fanlar
- Mikserler

Endüstri Uyumlu:

- ATEX II 2GD c T5

Özel tasarım seçenekleri:

- Rexnord Viva Oyuklu Hub
- Rexnord Viva Pozitif Hareketli Kaplin
- Rexnord Viva Anahtarsız Hub / Burç Tasarımı
- Sınırlı uç kayma
- Cıvatalı fren

Torque Demands Driven Machine



Typical Application for Electric Motor or Turbine Driven Equipment

Constant torque such as centrifugal pumps blowers and compressors

Typical Service Factor

1.0



Continuous duty with some torque variations including plastic extruders and forced draft fans

1.5



Light shock loads from metal extruders, cooling towers and log haulers

2.0



Moderate shock loading as expected from acar dumper, stone crusher, vibrating screen

2.5



Heavy shock load with some negative torques from reciprocating pumps, compressors, reversing turnout tables

3.0

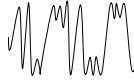

Frequent torque reversals such as reciprocating compressors with frequent torque reversals which do not necessarily include reverse rotations

Consult
Rexnord
Engineering

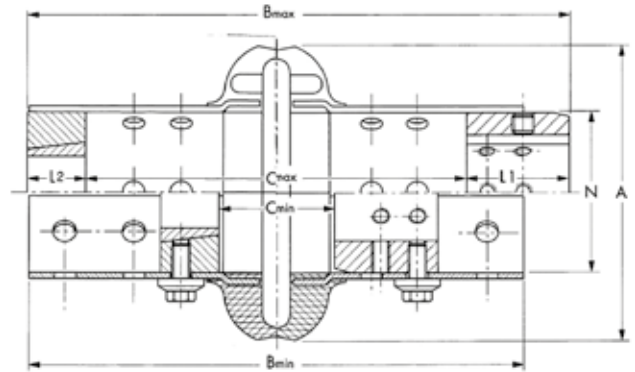
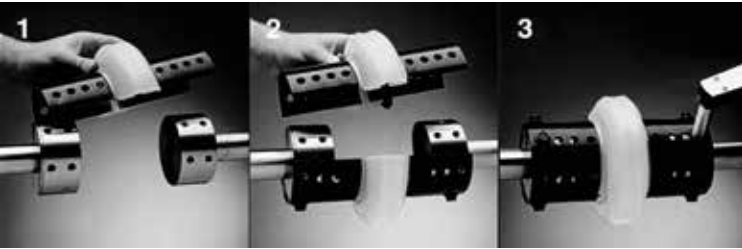

Coupling Size	Tnom		n max		Dmax		Taper		B		C(1)		C(2)		L1	L2	N	m*	J*
	Nm	min-1	mm	Bush	mm	mm	min.	max.	min.	max.	min.	max.							
	mm	mm	mm	mm	mm	mm	mm	mm	mm	mm	mm	mm	mm	mm	mm	mm	mm	kg	kgm ²
110	62	4 300	38	1 108	28	110	182	217	43	140	75	140	38	22	60	1,7	0,00148		
125	105	4 300	48	1 108	28	125	191	225	54	148	86	148	38	22	70	2,1	0,00254		
130	164	4 200	55	1 310	35	130	182	227	33	140	69	140	41	25	80	2,6	0,00378		
150	250	4 000	65	1 610	42	150	235	280	51	180	96	180	51	25	95	5,0	0,0100		
170	308	4 000	65	1 610	42	170	235	280	51	180	96	180	51	25	95	5,1	0,0113		
190	412	3 900	75	2 012	50	190	235	283	48	180	89	180	52	32	114	6,6	0,0213		
215	662	3 800	80	2 517	60	215	251	308	50	180	90	180	64	45	140	11	0,0430		
245	938	3 700	95	3 020	75	245	259	324	40	195	92	180	65	51	171	16	0,0947		
290	1412	3 600	110	3 020	75	290	315	403	80	257	132	250	73	51	215	29	0,240		
365	3200	2 600	127	3 535	90	365	368	480	67	250	66	250	90	90	235	52	0,493		
425	5580	1 800	155	4 040	100	425	368	524	54	250	45	250	114	102	285	97	1,340		
460	6270	1 800	165	4 545	110	460	368	548	67	250	20	250	124	114	302	110	1,980		

*weight (m) and inertia (J) with maximum bore and key way • Dimension (C1) finished bore hubs - C(2) with Taper Bush hubs

REXNORD OMEGA

Elastomer Coupling



ATEX II 2GD c T5



OMEGA
SERIES

Reliable Performance. Trusted Brands.



Design Features include:

- Split-in-half flex element design for simplified assembly and disassembly
- Torsionally soft flex element cushions shock loads and vibration, extending equipment life
- Interchangeable hubs allow for reduced inventory
- Polyurethane-to-metal bond eliminates assembly and slippage problems associated with mechanically clamped designs
- Material flexing design allows visual inspection during operation

Tasarım Özellikleri şunları içerir:

- İkiye bölünmüş esnek elemanın montaj ve demontaj kolaylığı
- Eğimli yumuşak elementin ani yüklemeleri ve titreşimleri absorbesi, uzun ömürlülük
- Değiştirilebilir göbekler
- Poliüretan-metal kemiğin mekanik olarak sıkıştırılması ile montaj ve kayma sorunlarını ortadan kaldırması
- Esnek malzeme tasarımı çalışma esnasında görsel incelemeye izin verir.

REXNORD OMEGA

ELASTOMERİK KAPLINLER

Applications:

- Pumps
- Compressors
- Industrial fans
- Mixers

Industry Compliant:

- ATEX II 2GD c T5

Special design options:

- Rexnord Omega HSU Element
- Rexnord Omega Heavy Duty Yellow Element
- Rexnord Omega Spline Bore Hub
- Rexnord Omega Positive Drive Coupling
- Rexnord Omega Keyless Hub / Bushing Design
- Rexnord Omega Light Duty Element
- Limited end float
- Bolt-on brake

Uygulamalar:

- Pompalar
- Kompresörler
- Endüstriyel fanlar
- Mikserler

Endüstri Uyumlu:

- ATEX II 2GD c T5

Özel tasarım seçenekleri:

- Rexnord Omega HSU Element
- Rexnord Omega Ağır İşler İçin Sarı Element
- Rexnord Omega Oyuklu Hub
- Rexnord Omega Pozitif Hareketli Kaplin
- Rexnord Omega Anahtarsız Hub / Burç Tasarımı
- Rexnord Omega Hafif İşler İçin Element
- Sınırlı uç kayma
- Cıvatalı fren

Torque Demands Driven Machine



Typical Application for Electric Motor or Turbine Driven Equipment

Constant torque such as centrifugal pumps blowers and compressors

Typical Service Factor

1.0



Continuous duty with some torque variations including plastic extruders and forced draft fans

1.5



Light shock loads from metal extruders, cooling towers and log haulers

2.0



Moderate shock loading as expected from a car dumper, stone crusher, vibrating screen

2.5



Heavy shock load with some negative torques from reciprocating pumps, compressors, reversing turnout tables

3.0

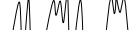

Frequent torque reversals such as reciprocating compressors with frequent torque reversals which do not necessarily include reverse rotations

Consult Rexnord Engineering

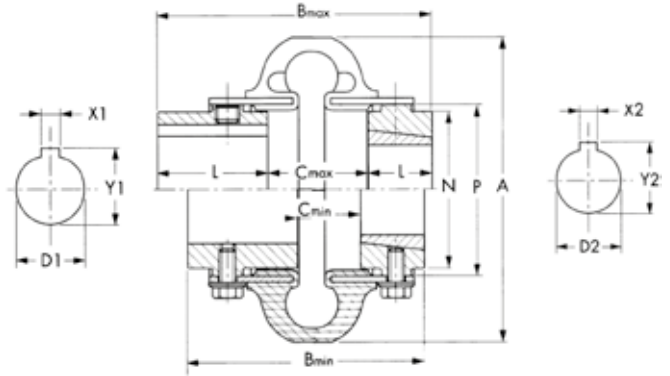
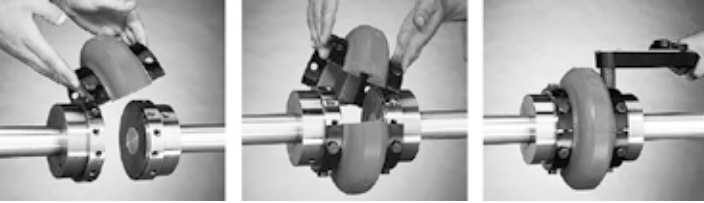

Coupling Size	Tnom	n max	Dmax	Taper	Dmax	A	B1		B2		C1		C2		L1	L2	N1	N2	P	m*	J*
							min.	max.	min.	max.	min.	max.	min.	max.							
							Nm	min-1	mm	Bush	mm	mm	mm	mm							
E2	22	7 500	28	-	-	89	84	94	-	-	36	46	-	-	24	-	38	-	47	0,5	0,00032
E3	41	7 500	34	1 008	25	102	84	122	87	87	8	46	43	43	38	22	50	50	59	1,0	0,00032
E4	62	7 500	42	1 008	25	116	84	122	87	87	8	46	43	43	38	22	57	57	66	1,3	0,0012
E5	105	7 500	48	1 210	32	137	97	147	103	103	8	59	52	52	44	25	70	71	80	2,3	0,0032
E10	164	7 500	55	1 610	42	162	97	147	103	103	8	59	52	52	44	25	84	84	93	3,4	0,0064
E20	260	6 600	60	1 610	42	184	113	169	114	114	9	65	64	64	52	25	95	89	114	6,8	0,016
E30	412	5 800	75	2 012	50	210	125	185	128	128	7	68	64	64	59	32	114	102	138	10	0,034
E40	622	5 000	85	2 517	65	241	135	201	150	150	9	75	60	60	63	45	146	117	168	17	0,080
E50	864	4 200	90	2 517	65	279	151	231	165	165	11	91	76	76	70	45	152	124	207	24	0,158
E60	1 412	3 800	105	3 020	75	318	173	261	186	186	9	97	84	84	82	51	165	146	222	34	0,266
E70	2 490	3 600	120	3 535	90	356	189	279	238	238	19	109	60	60	85	89	175	165	235	39	0,366
E80	4 460	2 000	155	4 040	100	406	245	377	299	299	17	149	95	95	114	102	240	194	286	77	1,054
E100	9 600	1 900	171	4 545	110	533	324	375	267	267	44	95	38	152	140	114	260	260	359	95	2,19
E120	19 200	1 800	190	5 050	125	635	362	429	305	305	57	127	51	181	152	127	299	299	448	163	2,93
E140	38 400	1 500	229	7 060	177	762	432	483	381	381	76	127	76	178	178	152	381	381	530	280	4,00

*Weight (m) and inertia (J) with maximum bore and key way • Dimension B1, C1, D1, L1, N1 finished bore hubs - B2, C2, D2, L2, N2 with Taper Bush hub

REXNORD OMEGA ES

Elastomer Coupling



ATEX II 2GD c T5



OMEGA ES SERIES

Reliable Performance. Trusted Brands.



Design Features include:

- Split-in-half flex element design for simplified assembly and disassembly
- Torsionally soft flex element cushions shock loads and vibration, extending equipment life
- Interchangeable hubs allow for reduced inventory
- Polyurethane-to-metal bond eliminates assembly and slippage problems associated with mechanically clamped designs
- Material flexing design allows visual inspection during operation

Tasarım Özellikleri şunları içerir:

- İkiye bölünmüş esnek elemanın montaj ve demontaj kolaylığı
- Eğimli yumuşak elementin ani yüklemeleri ve titreşimleri absorbesi, uzun ömürlülük
- Değiştirilebilir göbekler
- Poliüretan-metal kemiğin mekanik olarak sıkıştırılması ile montaj ve kayma sorunlarını ortadan kaldırması
- Esnek malzeme tasarımı çalışma esnasında görsel incelemeye izin verir.

REXNORD OMEGA ES ELASTOMERİK KAPLINLER

Applications:

- Pumps
- Compressors
- Industrial fans
- Mixers

Industry Compliant:

- ATEX II 2GD c T5

Special design options:

- Rexnord Omega HSU Element
- Rexnord Omega Heavy Duty Yellow Element
- Rexnord Omega Spline Bore Hub
- Rexnord Omega Positive Drive Coupling
- Rexnord Omega Keyless Hub / Bushing Design
- Rexnord Omega Light Duty Element
- Limited end float
- Bolt-on brake

Uygulamalar:

- Pompalar
- Kompresörler
- Endüstriyel fanlar
- Mikserler





Endüstri Uyumlu:

- ATEX II 2GD c T5

Özel tasarım seçenekleri:

- Rexnord Omega HSU Element
- Rexnord Omega Ağır İşler İçin Sarı Element
- Rexnord Omega Oyuklu Hub
- Rexnord Omega Pozitif Hareketli Kaplin
- Rexnord Omega Anahtarsız Hub / Burç Tasarımı
- Rexnord Omega Hafif İşler İçin Element
- Sınırlı uç kayma
- Cıvatalı fren

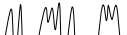

Torque Demands Driven Machine	Typical Application for Electric Motor or Turbine Driven Equipment	Typical Service Factor
	Constant torque such as centrifugal pumps blowers and compressors	1.0
	Continuous duty with some torque variations including plastic extruders and forced draft fans	1.5
	Light shock loads from metal extruders, cooling towers and log haulers	2.0
	Moderate shock loading as expected from a car dumper, stone crusher, vibrating screen	2.5
	Heavy shock load with some negative torques from reciprocating pumps, compressors, reversing turnout tables	3.0
	Frequent torque reversals such as reciprocating compressors with frequent torque reversals which do not necessarily include reverse rotations	Consult Rexnord Engineering

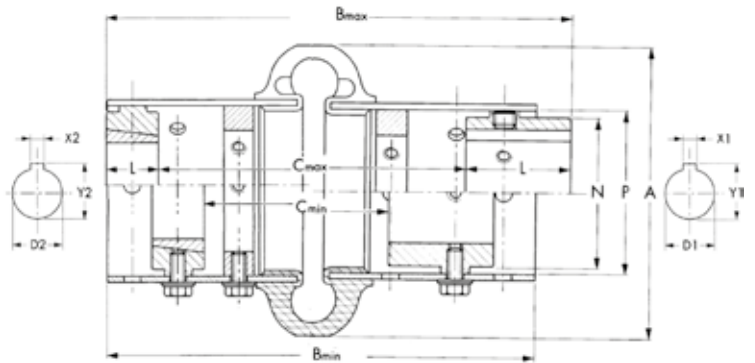

TECHNICAL SPEC

Coupling Size	Tnom	n max	Dmax	Taper	max	A	B1		B2		C1		C2		L1	L2	N1	N2	P	m*	J*
							min.	max.	min.	max.	min.	max.	min.	max.							
	Nm	min-1	mm	Bush	mm	mm	mm	mm	mm	mm	mm	mm	mm	mm	mm	mm	mm	mm	kg	kgm ²	
ES2-R	22	7 500	28	-	-	89	146	149	-	-	91	100	-	-	24	-	38	-	47	1,1	0,0005
ES3-R	41	7 500	34	1 008	25	102	184	216	184	184	85	140	97	137	38	22	50	50	59	2,3	0,0017
ES4-R	62	7 500	42	1 008	25	116	184	216	184	184	85	140	97	137	38	22	57	57	66	2,8	0,0027
ES5-R	105	7 500	48	1 210	32	137	184	228	184	184	89	140	94	133	44	25	70	71	80	4,1	0,0059
ES10-R	164	7 500	55	1 610	42	162	184	228	184	184	89	140	94	133	44	25	84	84	93	5,4	0,010
ES20	260	4 800	60	1 610	42	184	238	280	238	238	67	180	123	172	52	25	95	89	114	8,2	0,021
ES30	412	4 200	75	2 012	50	210	238	293	238	238	54	180	117	165	59	32	114	102	138	12	0,044
ES40	622	3 600	85	2 517	65	241	238	307	238	244	41	180	104	153	63	45	146	117	168	19	0,099
ES50	864	3 100	90	2 517	65	279	238	319	238	244	28	180	104	153	70	45	152	124	207	27	0,19
ES60	1 412	2 800	105	3 020	75	318	318	415	318	326	66	250	155	223	82	51	165	146	222	39	0,34
ES70	2 490	2 600	120	3 535	90	356	318	421	318	364	59	250	116	185	85	89	175	165	235	46	0,47
ES80	4 460	1 800	155	4 040	100	406	318	478	318	377	37	250	104	172	114	102	240	194	286	82	1,14

*Weight (m) and inertia (J) with maximum bore and key way • Dimension B1, C1, D1, L1, N1 finished bore hubs - B2, C2, D2, L2, N2 with Taper Bush hubs

REXNORD FALK WRAPFLEX

Elastomer Coupling



ATEX II 2GD c T5



FALK
WRAPFLEX
SERIES

Reliable Performance. Trusted Brands.



| Design Features include:

- Replace-in-place design allows quick & easy element replacement without having to move the hubs
- High capacity ratings at a very competitive price
- Polyurethane element has excellent wear and chemical resistance and an operating temperature range of -40°F to 200°F

| Tasarım Özellikleri şunları içerir:

- Hubları çıkarmadan yerinde montaj ve demontaj kolaylığı
- Yüksek kapasite oranları ve çok rekabetçi fiyat
- Poliüretan elemanın kimyasal ve aşınmaya karşı direnci ve -40 derece ile 95 derece arasında çalışması

REXNORD FALK WRAPFLEX ELASTOMERİK KAPLINLER

Applications:

- Pumps
- Compressors
- General Purpose Machinery

Industry Compliant:

- ATEX II 2GD c T5





Uygulamalar:

- Pompalar
- Kompresörler
- Genel Amaçlı Makineler

Endüstri Uyumlu:

- ATEX II 2GD c T5

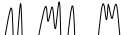

Torque Demands Driven Machine	Typical Application for Electric Motor or Turbine Driven Equipment	Typical Service Factor
	Constant torque such as centrifugal pumps blowers and compressors	1.0
	Continuous duty with some torque variations including plastic extruders and forced draft fans	1.5
	Light shock loads from metal extruders, cooling towers and log haulers	2.0
	Moderate shock loading as expected from a car dumper, stone crusher, vibrating screen	2.5
	Heavy shock load with some negative torques from reciprocating pumps, compressors, reversing turnout tables	3.0
	Frequent torque reversals such as reciprocating compressors with frequent torque reversals which do not necessarily include reverse rotations	Consult Rexnord Engineering

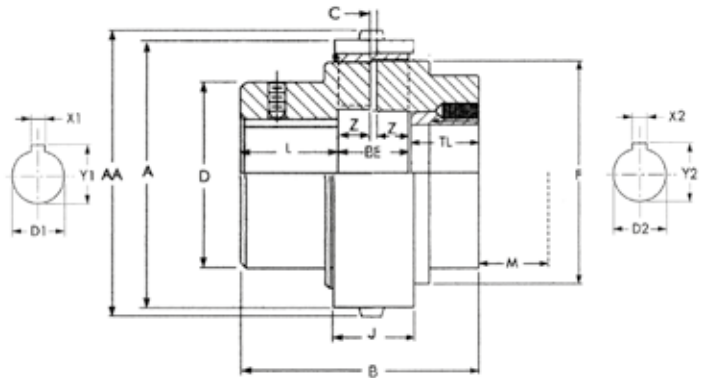

Wrapflex Size	Tnom	n max	D1		D2		A		AA		B										m*	
			max	Taper	max	max	Nylon	Steel	Nylon	Steel	(1)	(2)	BE	C	D	L	TL	M	F	Z	Nylon	Steel
			Nm	min-1	mm	Bush	mm	mm		mm		mm		mm								kg
5R	62	4 500	38	1108	28	77	77	81	81	72	65	20	2	60	26	23	19	64	9	1,3	1,5	
10R	130	4 500	48	1210	32	91	91	95	95	90	90	24	2	72	34	33	27	76	11	2,5	2,7	
20R	320	4 500	60	1610	40	126	124	132	130	124	98	32	2	92	45	33	27	102	15	5,6	6,1	
30R	520	4 500	65	2012	48	147	143	153	149	152	120	36	2	105	58	42	35	118	17	9,4	10	
40R	1 030	3 600	85	2517	60	182	177	190	185	181	139	47	5	130	67	46	42	150	21	17	18	
50R	2 500	3 000	105	3020	75	231	224	239	232	215	171	61	5	170	77	55	53	190	28	34	36	
60R	4 000	2 500	135	4030	100	-	267	-	278	275	245	75	5	200	100	85	86	228	35	-	62	
70R	8 000	2 100	160	4535	110	-	310	-	321	324	264	84	5	227	120	90	104	270	40	-	98	
80R	15 000	1 800	190	5040	125	-	370	-	381	376	305	97	6	270	140	104	123	328	45	-	165	

Weight (m) on maximum bore and key way • Dimension B(1), D1 finished bore hubs - B(2), D2 with Taper Bush hubs

REXNORD FALK STEELFLEX

Grid Coupling



ATEX II 2GD c T6



FALK STEELFLEX SERIES

Reliable Performance. Trusted Brands.

Tapered T-Grid profile fits smoothly into hub for easy installation and maintenance

Durable, Nitrile seals prevent loss of lubricant and entrance of water, dust or other materials

Made of steel for maximum strength; machined to within 0.001 inches, permitting utilization of any hub surface for measurement of shaft alignment

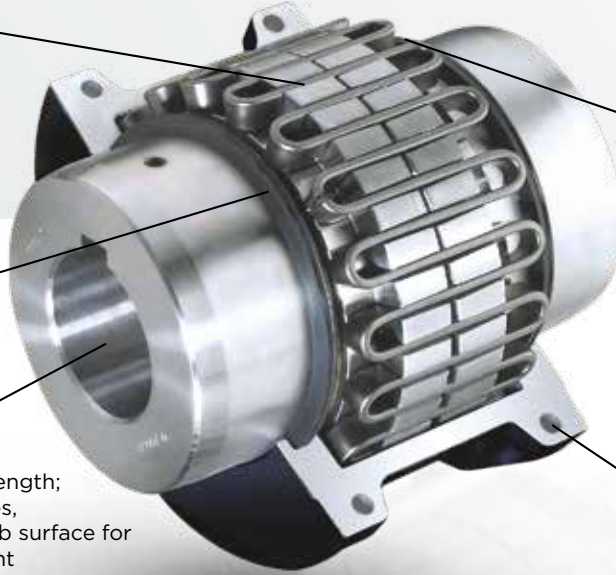

High-strength alloy steel grids are tempered to spring hardness and precision shot-peened for increased fatigue strength protecting equipment against shock and vibratory conditions

Grade 5 cap screws ensure holding power to fasten the cover

Design Features include:

- Long life with alloy steel tapered grids
- Extended maintenance periods with the use of falk long term grease
- Easy maintenance with the replace-in-place design
- Absorbs shock loads and offers vibration damping with the original Falk Steelflex T-GRID design

Tasarım Özellikleri şunları içerir:

- Alaşımli çelikle uzun ömür konik yaylar
- Falk uzun dönem gres yağı kullanımı ile uzun süreli bakım
- Yerinde değiştirme kolay tasarımı
- Orijinal Steelflex T-GRID tasarımı ile ani yükleri ve vibrasyonları absorbe etme

Applications:

- Paper machines
- Ball mills
- Hot bed rolls
- Slurry pumps
- Conveyors
- Blowers and fans
- Centrifugal pumps

Industry Compliant:

- ATEX II 2GD c T6

Special design options:

- Type T63 disc brake
- Type T90 flywheel
- Type BW brake wheel
- In total 12 models to choose from

Uygulamalar:

- Kağıt makineleri
- Bilyalı değirmenler
- Sıcak yatak hadeleme
- Karıştırıcı pompaları
- Konveyörler
- Ventilator ve fanlar
- Santrifuj pompalar

Endüstri Uyumlu:





- ATEX II 2GD c T6

Özel tasarım seçenekleri:

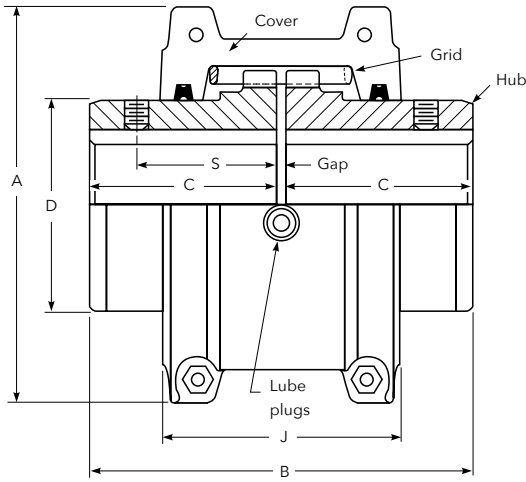
- Tip T63 disk fren
- Tip T90 volan
- BW tipi fren çarkı
- 12 model seçim uygunluğu

REXNORD FALK STEELFLEX
ÇELİK YAYLI KAPLINLER

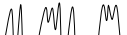

Torque Demands Driven Machine	Typical Application for Electric Motor or Turbine Driven Equipment	Typical Service Factor
	Constant torque such as centrifugal pumps blowers and compressors	1.0
	Continuous duty with some torque variations including plastic extruders and forced draft fans	1.5
	Light shock loads from metal extruders, cooling towers and log haulers	2.0
	Moderate shock loading as expected from a car dumper, stone crusher, vibrating screen	2.5
	Heavy shock load with some negative torques from reciprocating pumps, compressors, reversing turnout tables	3.0
	Frequent torque reversals such as reciprocating compressors with frequent torque reversals which do not necessarily include reverse rotations	Consult Rexnord Engineering

TECHNICAL SPEC

Coupling Size	Torque Rating	Max. Allowed Speed	Min. Bore	Max. Bore	Grap	A	B	C	D	J	S	Lube Weight	Coupling weight with no bore
	Nm	rpm	mm	mm	mm	mm					kg	kg	
1020T	52	4 500	13	28	3	97	98	47	39	66	39,1	0,02	1,9
1030T	149	4 500	13	35	3	105	98	47	49	68	39,1	0,04	2,5
1040T	249	4 500	13	43	3	114	104	50	57	69	40,1	0,05	3,3
1050T	435	4 500	13	50	3	135	123	60	66	80	44,7	0,06	5,4
1060T	684	4 350	20	56	3	147	130	63	76	93	52,3	0,08	7,4
1070T	994	4 125	20	67	3	158	155	76	87	96	53,8	0,1	10,4
1080T	2 050	3 600	27	80	3	190	180	88	104	115	64,5	0,1	17,9
1090T	3 730	3 600	27	95	3	211	199	98	123	122	71,6	0,2	25,6
1100T	6 280	2 440	42	110	5	251	246	120	142	155	0,4	42,0
1110T	9 320	2 250	42	120	5	269	259	127	160	161	0,5	54,3
1120T	13 700	2 025	61	140	6	307	304	149	179	191	0,7	81,2
1130T	19 900	1 800	67	170	6	345	329	161	217	195	0,9	121
1140T	28 600	1 650	67	200	6	384	374	184	254	201	1,1	178
1150T	39 800	1 500	108	215	6	453	371	182	269	271	1,9	234
1160T	55 900	1 350	121	240	6	501	402	198	304	278	2,8	317
1170T	74 600	1 225	134	280	6	566	437	215	355	307	3,4	448
1180T	103 000	1 100	153	300	6	629	483	238	393	321	3,7	619
1190T	137 000	1 050	153	335	6	675	524	259	436	325	4,4	776
1200T	186 000	900	178	360	6	756	564	279	497	355	5,6	1 058
1210T	249 000	820	178	390	13	844	622	304	533	431	10,5	1 424
1220T	336 000	730	203	420	13	920	663	325	571	490	16,1	1 785
1230T	435 000	680	203	450	13	1 003	703	345	609	546	24,0	2 267
1240T	559 000	630	254	480	13	1 087	749	368	647	647	33,8	2 950
1250T	746 000	580	254		13	1 181	815	401	711	698	50,1	3 833
1260T	932 000	540	254		13	1 260	876	431	762	762	67,2	4 682

REXNORD FALK LIFELIGN

Gear Coupling



ATEX II 2GD c T5



FALK
LIFELIGN
SERIES

Reliable Performance. Trusted Brands.

Reduced head capscrews and non-turning locknut allow one-wrench tightening

Triple-crowned AGMA 20° tooth design with crowning at the root, tip and face of each tooth

Viton® seals provide long life in high temperature applications and four-point seal improves lubrication retention during misalignment conditions

Lubrication plug locations are ideal for effective application of grease



Design Features include:

- The high torque ratings and large bore capacities result in savings of up to 35% compared to the competition
- Long Term Grease (LTG) lubrication and a four-point seal provide maximum lubrication retention, extend the coupling life and contribute to reduced maintenance needs.
- 3 year heavy duty warranty when used with LTG
- Lifelign's triple-crowned teeth are crowned on the root, tip and face to articulate freely, minimizing wear caused by misalignment. The triplecrowned teeth protects equipment from damaging loads by eliminating tiploading while reducing backlash and radial clearances.

Tasarım Özellikleri şunları içerir:

- Yüksek tork değerleri ve diğerlerine kıyasla %35 daha büyük işleme kapasitesi
- Uzun dönem gres yağının maksimum koruma sağlanması, bakımının geç yapılma kolaylığı
- LTG ile kullanıldığında 3 yıllık ağır hizmet garantisi
- Lifelign'in kaçıklıkları, geri tepmeleri, ani yükleri absorbe edip koruyucu özellik sağlaması

REXNORD FALK LIFELIGN DİŞLİ KAPLINLER

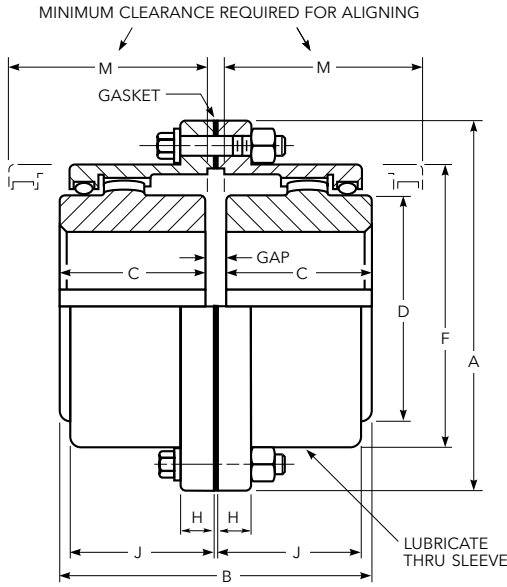

Torque Demands Driven Machine

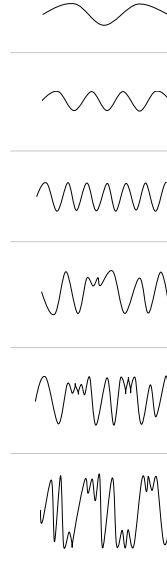

Typical Application for Electric Motor or Turbine Driven Equipment

Constant torque such as centrifugal pumps blowers and compressors	1.0
Continuous duty with some torque variations including plastic extruders and forced draft fans	1.5
Light shock loads from metal extruders, cooling towers and log haulers	2.0
Moderate shock loading as expected from a car dumper, stone crusher, vibrating screen	2.5
Heavy shock load with some negative torques from reciprocating pumps, compressors, reversing turnout tables	3.0
Frequent torque reversals such as reciprocating compressors with frequent torque reversals which do not necessarily include reverse rotations	Consult Rexnord Engineering

Applications:

- Pumps
- Paper machines
- Conveyors
- Pulpers
- Crushers

Uygulamalar:

- Pompalar
- Kağıt makineleri
- Konveyörler
- Pulper
- Kırıcılar

Industry Compliant:

- ATEX II 2GD c T5

Endüstri Uyumlu:

- ATEX II 2GD c T5

Special design options:

- Brakes adapters
- Axial slide couplings
- Floating shaft assemblies
- Electrically insulated

Özel tasarım seçenekleri:

- Fren adaptörleri
- Eksenel sürgülü kaplinler
- Yüzer shaft tertibatları
- Elektrik yalıtımlı



B B C C

Coupling Size	Torque Rating	Max Allowed Speed	Min Bore	Max Bore	Gap	A	B		C		D	F	H	J	M	Lube Weight	Coupling Weight* with no bore
							Std Hub	Long Hub	Std Hub	Long Hub							
G20	Nm	rpm	mm	mm	mm	mm	mm				mm	mm	mm	mm	mm	kg	kgm ²
1010G	1 140	8 000	13	50	3	115	88	206,2	42	101,6	68	83	14	39	51	0,04	4,5
1015G	2 350	6 500	20	65	3	152	101	231,6	49	114,3	86	105	19	48	61	0,07	9,0
1020G	4 270	5 600	26	78	3	177	127	263,0	62	130,0	105	126	19	59	77	0,11	15,9
1025G	7 470	5 000	32	98	5	212	158	303,8	77	149,4	130	154	21	72	92	0,21	29,5
1030G	12 100	4 400	39	111	5	239	187	335,2	91	165,1	152	180	21	84	107	0,36	43,1
1035G	18 500	3 900	51	134	6	279	218	374,4	106	184,2	177	211	28	98	130	0,54	68,0
1040G	30 600	3 600	64	160	6	317	247	412,4	120	203,2	209	245	28	111	145	0,90	97,5
1045G	42 000	3 200	77	183	8	346	277	496,6	134	244,3	235	274	28	123	166	1,00	136
1050G	56 600	2 900	89	200	8	388	314	598,2	153	295,1	254	305	38	141	183	1,70	191
1055G	74 000	2 650	102	220	8	425	344	604,8	168	298,4	279	334	38	158	204	2,20	249
1060G	90 400	2 450	115	244	8	457	384	617,6	188	304,8	304	366	25	169	229	3,10	306
1070G	135 000	2 150	127	289	10	527	451	629,8	220	309,9	355	424	28	196	267	4,20	485

TECHNICAL SPEC

REXNORD THOMAS XTSR71

Disc Coupling



ATEX II 2GD c T6



THOMAS
XTSR71
SERIES

Reliable Performance. Trusted Brands.



Design Features include:

- Optimum torque density providing low overhung loads/lower cost of ownership
- Tapered bolt design providing quick installation without damaging the disc pack
- Standard hardware balancing requires no special tooling
- Longer life due to standard overload bushings
- Manganese Phosphate standard protective coating

Tasarım Özellikleri şunları içerir:

- Optimum tork yoğunluğu
- Konik geçme ile disklere zarar vermeden hızlı yükleme sağlamak
- Standart donanım özel alet ile dengeleme gerektirmez.
- Standart aşırı yükleme burçları ile uzun ömür
- Manganez Fosfat standart koruyucu kaplama

Applications:

- Pumps
- Compressors
- Fans
- Synchronized rollers
- Wire Feeders
- Blowers

Industry Compliant:

- API 671/ISO 10441 (when specified)
- API 610/ISO 13709
- ISO 14691
- ATEX II 2GD c T6

Special design options:

- Electrically insulated
- Torsionally adjusted
- Limited end float
- Torque meter
- Reduced sparking

Uygulamalar:

- Pompalar
- Kompresörler
- Hayranlar
- Senkronize silindirler
- Tel Besleyiciler
- Vantilatör

Endüstri Uyumlu:





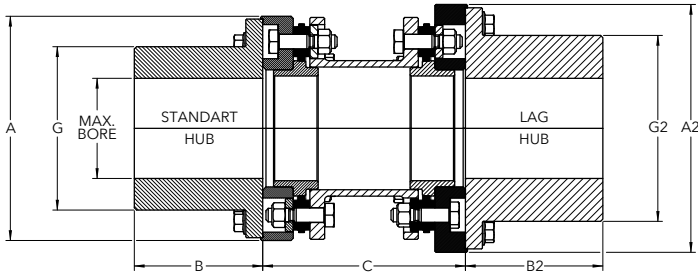

- API 671 / ISO 10441 (belirtildiğinde)
- API 610 / ISO 13709
- ISO 14691
- ATEX II 2GD c T6

Özel tasarım seçenekleri:

- Elektrik yalıtımlı
- Burulma ayarlı
- Sınırlı uç kayma
- Tork ölçer
- Daha az kıvılcım

REXNORD THOMAS XTSR71
DİSK KAPLINLER



Torque Demands Driven Machine	Typical Application for Electric Motor or Turbine Driven Equipment	Typical Service Factor
	Constant torque such as centrifugal pumps blowers and compressors	1.0
	Continuous duty with some torque variations including plastic extruders and forced draft fans	1.5
	Light shock loads from metal extruders, cooling towers and log haulers	2.0
	Moderate shock loading as expected from a car dumper, stone crusher, vibrating screen	2.5
	Heavy shock load with some negative torques from reciprocating pumps, compressors, reversing turnout tables	3.0
	Frequent torque reversals such as reciprocating compressors with frequent torque reversals which do not necessarily include reverse rotations	Consult Rexnord Engineering

TECHNICAL SPEC

Coupling Size**	Max. Bore Std Hub (SH)	Max. Bore XL Hub	Max. Bore XXL Hub	A SH	A XL	A XXL	B SH	B XL	B XXL	Min C	G SH	G XL	G XXL
	mm	mm	mm	mm	mm	mm	mm	mm	mm	mm	mm	mm	mm
726	42	55	65	95	108	129	35	42	51	65	59	73	86
826	52	65	77	108	129	140	42	51	82	77	73	86	104
996	61	76	95	129	140	166	51	82	95	92	86	104	123
1088	76	95	110	140	166	199	82	95	114	96	104	123	145
1298	90	110	125	166	199	220	95	114	122	115	123	145	165
1548	105	125	135	199	220	245	114	122	135	135	145	165	182
1698	125	135	155	220	245	264	122	135	155	151	165	182	200
1928	135	155	175	245	264	291	135	155	167	161	182	200	220
2068	150	170	185	264	291	313	155	167	190	187	200	220	236
2278	155	180	225	291	313	345	167	190	185	196	220	236	280
2468	166	220	250	313	345	381	190	185	200	209	236	280	308
2698	200	245	270	345	381	405	185	200	191	236	280	308	332
2888	220	260	280	381	405	437	200	191	225	255	308	332	355
3058	235	280	310	405	437	482	191	225	257	257	332	355	398
3358	260	300	330	437	482	503	225	257	249	287	355	398	419
3668	285	320	350	482	503	529	257	249	266	310	398	419	444

Coupling Size**	Max kW / 100 RPM	Max. RPM		Max. Continuous Torque	Peak Overload Torque	Weight*	Weight Change Per mm of "C"	WR ² *	WR ² Change Per mm of "C"	Axial Capacity
		Not Balanced	Balanced							
726	3,1	12000	20000	297	594	3,1	0,00311	0,00364	0,000002	±1,3
826	5,8	10900	18500	554	1110	5,0	0,00535	0,00770	0,000005	±1,5
996	9,7	9800	15000	927	1850	8,4	0,00503	0,01880	0,000007	±1,8
1088	23,0	9000	14000	2190	4390	12,5	0,00966	0,0336	0,000014	±1,3
1298	37,2	8000	12000	3550	7100	20,6	0,0118	0,0796	0,000027	±1,6
1548	61,9	7100	10000	5910	11800	34,6	0,0161	0,1890	0,000053	±1,8
1698	85,7	6600	9100	8190	16400	47,0	0,0214	0,318	0,000083	±2,0
1928	116,0	6100	8500	11100	22200	62,7	0,0251	0,533	0,000129	±2,3
2068	161,0	5800	7800	15400	30700	84,9	0,0325	0,840	0,000188	±2,5
2278	209,0	5500	7100	19900	39900	110,0	0,0378	1,300	0,000268	±2,7
2468	274,0	5200	6500	26200	52400	143,0	0,0451	1,94	0,000379	±3,0
2698	376,0	4800	6000	35900	71900	184,0	0,0572	3,30	0,000561	±3,2
2888	492,0	4600	5700	47000	94000	257,0	0,0716	5,35	0,000771	±3,5
3058	545,0	4400	5400	52000	104000	274,0	0,0723	6,80	0,000918	±3,7
3358	735,0	4200	4700	70200	140000	366,0	0,0907	10,40	0,00138	±4,0
3668	987,0	3900	4400	94300	189000	521,0	0,111	17,60	0,00202	±4,4

* Weight and WR² calculated with standard adapters at minimum C dimension and with max. bore. / ** Sizes up to 283 000 Nm and max bore 430 mm

REXNORD THOMAS XTSR52

Disc Coupling



ATEX II 2GD c T6



THOMAS
XTSR52
SERIES

Reliable Performance. Trusted Brands.



Design Features include:

- Optimum torque density providing low overhung loads/lower cost of ownership
- Unitized disc pack for easy installation
- Tapered bolt design providing quick installation without damaging the disc pack
- Manganese Phosphate standard protective coating

Tasarım Özellikleri şunları içerir:

- Optimum tork yoğunluğu
- Birimleştirilmiş disk packler ile kolay montaj
- Konik geçme ile disklere zarar vermeden hızlı montaj sağlamak
- Manganez Fosfat standart koruyucu kaplama

Applications:

- Pumps
- Compressors
- Fans
- Synchronized rollers
- Wire Feeders
- Blowers

Industry Compliant:

- API 671/ISO 10441 (when specified)
- API 610/ISO 13709
- ISO 14691
- ATEX II 2GD c T6

Special design options:

- Electrically insulated
- Torsionally adjusted
- Limited end float
- Torque meter
- Reduced sparking

Uygulamalar:

- Pompalar
- Kompresörler
- Hayranlar
- Senkronize silindirlir
- Tel Besleyiciler
- Ventilator

Endüstri Uyumlu:





- API 671 / ISO 10441 (belirtildiğinde)
- API 610 / ISO 13709
- ISO 14691
- ATEX II 2GD c T6

Özel tasarım seçenekleri:

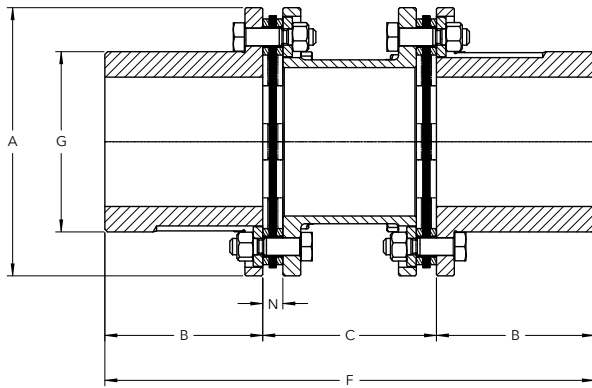
- Elektrik yalıtımlı
- Burulma ayarlı
- Sınırlı uç kayma
- Tork ölçer
- Daha az kıvılcım

REXNORD THOMAS XT5R52
DİSK KAPLINLER

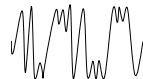

Torque Demands Driven Machine	Typical Application for Electric Motor or Turbine Driven Equipment	Typical Service Factor
	Constant torque such as centrifugal pumps blowers and compressors	1.0
	Continuous duty with some torque variations including plastic extruders and forced draft fans	1.5
	Light shock loads from metal extruders, cooling towers and log haulers	2.0
	Moderate shock loading as expected from a car dumper, stone crusher, vibrating screen	2.5
	Heavy shock load with some negative torques from reciprocating pumps, compressors, reversing turnout tables	3.0
	Frequent torque reversals such as reciprocating compressors with frequent torque reversals which do not necessarily include reverse rotations	Consult Rexnord Engineering

	Coupling Size**	Max. Bore	A	B	Standard "C" Dimensions				Min C	F	G	N
		mm	mm	mm	100	140	180	250	mm	mm	mm	mm
TECHNICAL SPEC	726	45	95	30	•				40	152	63,8	8,6
	826	50	108	50	•	•			47	173	71,8	9,3
	996	60	129	50	•	•	•		54	202	84,4	9,6
	1088	65	140	81	•	•	•	•	58	220	92,1	10,4
	1298	80	166	97		•	•	•	70	264	110,6	12,9
	1548	95	197	97		•	•	•	81	313	132,4	14,8
	1698	105	218	110					89	345	146,9	15,8
	1928	120	245	110					96	390	167,7	17,1
	2068	130	264	125					109	421	178,6	18,4
	2278	140	291	145					115	459	196,7	19,2
	2468	150	313	150					123	497	213,5	20,5
	2698	165	343	150					139	545	232,1	23,5
	2888	175	371	175					151	591	246,0	25,2
	3058	185	395	185					152	622	263,0	25,2
3358	205	427	245					168	682	288,1	27,3	
3668	225	466	281					184	746	315,2	30,4	

Coupling Size**	Max kW / 100 RPM	Max. RPM		Max. Continuous Torque	Peak Overload Torque	Weight*	Weight Change Per mm of "C"	WR ² *	WR ² Change Per mm of "C"	Axial Capacity
		1,0	Not Balanced							
726	3,11	12000	20000	297	594	2,23	0,00363	0,00247	0,00000218	±1,3
826	5,8	10900	18500	554	1110	3,4	0,0056	0,0050	0,0000046	±1,5
996	9,7	9800	15000	927	1850	5,6	0,0051	0,0114	0,0000061	±1,8
1088	23,0	9000	14000	2190	4390	7,9	0,0098	0,0193	0,0000130	±1,3
1298	37,2	8000	12000	3550	7100	13,5	0,0123	0,0471	0,0000252	±1,6
1548	61,9	7100	10000	5910	11800	22,1	0,0176	0,1100	0,0000528	±1,8
1698	85,7	6600	9100	8190	16400	30,1	0,0219	0,1830	0,0000773	±2,0
1928	116,0	6100	8500	11100	22200	43,3	0,0268	0,3330	0,000124	±2,3
2068	161,0	5800	7800	15400	30700	54,5	0,0339	0,4890	0,000177	±2,5
2278	209,0	5500	7100	19900	39900	72,1	0,0395	0,7820	0,000254	±2,7
2468	274,0	5200	6500	26200	52400	92,1	0,0475	1,1600	0,000365	±3,0
2698	376,0	4800	6000	35900	71900	121,0	0,0606	1,8500	0,000544	±3,2
2888	492,0	4600	5700	47000	94000	156,0	0,0777	2,7600	0,000759	±3,5
3058	545,0	4400	5400	52000	104000	183,0	0,0771	3,6200	0,000899	±3,7
3358	735,0	4200	4700	70200	140000	237,0	0,0958	5,5900	0,00134	±4,0
3668	987,0	3900	4400	94300	189000	311,0	0,1170	8,8000	0,00196	±4,4

Weight and WR² calculated at minimum DBSE and Max. Bore. / ** Sizes up to 283 000 Nm and max bore 320 mm

REXNORD THOMAS SR71

Disc Coupling



ATEX II 2GD c T5



THOMAS SR71
SERIES

Reliable Performance. Trusted Brands.



Design Features include:

- Unitized and piloted center member allowing easy installation and repeatable balance
- Bolt on hubs for oversize bore capacity
- Unique jacking bolt feature compressing coupling for easy installation and removal of center member assembly

Tasarım Özellikleri şunları içerir:

- Birleştirilmiş ve pilot merkeze kolay izin veren kurulum ve tekrarlanabilir denge
- Büyük boy için göbeklerde civata delik kapasitesi
- Kaplini sıkıştırmak için benzersiz kriko civatası özelliği

Applications:

- Pumps
- Compressors
- Fans
- Paper Machines
- Synchronized rollers
- Wire Feeders
- Blowers

Industry Compliant:

- API 671/ISO 10441 (when specified)
- API 610/ISO 13709
- ISO 14691
- ATEX II 2GD c T5

Special design options:

- Torsionally adjusted
- Limited end float
- Torque meter
- Reduced sparking

Uygulamalar:

- Pompalar
- Kompresörler
- Hayranlar
- Kağıt Makineleri
- Senkronize silindirler
- Tel Besleyiciler
- Vantilatörler

Endüstri Uyumlu:





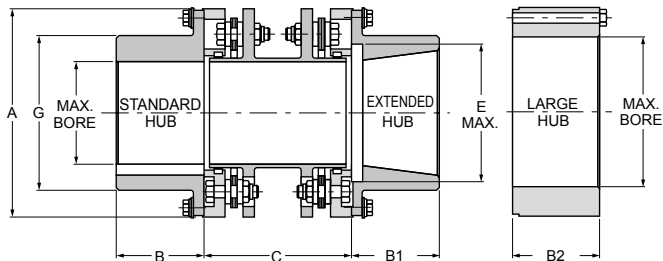

- API 671 / ISO 10441 (belirtildiğinde)
- API 610 / ISO 13709
- ISO 14691
- ATEX II 2GD c T5

Özel tasarım seçenekleri:

- Elektrik yalıtımlı
- Burulma ayarlı
- Sınırlı uç kayma
- Tork ölçer
- Daha az kıvılcım

REXNORD THOMAS SR71
DİSK KAPLINLER



Torque Demands Driven Machine	Typical Application for Electric Motor or Turbine Driven Equipment	Typical Service Factor
	Constant torque such as centrifugal pumps blowers and compressors	1.0
	Continuous duty with some torque variations including plastic extruders and forced draft fans	1.5
	Light shock loads from metal extruders, cooling towers and log haulers	2.0
	Moderate shock loading as expected from a car dumper, stone crusher, vibrating screen	2.5
	Heavy shock load with some negative torques from reciprocating pumps, compressors, reversing turnout tables	3.0
	Frequent torque reversals such as reciprocating compressors with frequent torque reversals which do not necessarily include reverse rotations	Consult Rexnord Engineering

Standard "C" Dimensions B&B 1 Hub B2 Hub

Coupling Size**	100	140	180	250	Max. Bore	Max. Bore	A	B	B1	B2	Min C	Max. E	G
	mm				mm		mm				mm	mm	mm
	TECHNICAL SPEC												
150	•	•	•		39	64	91	33,3	42,9	41,1	87	52	59
175	•	•	•	•	50	73	106	39,6	52,3	46	87	65	71
225	•	•	•	•	58	87	125	50,8	63,5	52,3	87	78	85
300		•	•	•	81	110	152	66,5	82,6	69,9	102	105	113
350			•	•	95	120	171	79,2	95,3	76,2	124	127	133
375					100	137	194	82,6	101,6	82,6	127	135	144
412					110	145	203	91,9	111,3	91,9	155	146	155
462					130	166	229	104,6	127	104,6	178	160	174
512					140	187	255	114,3	136,7	114,3	191	179	194
562					156	200	279	127,0	152,4	127	203	195	213
600					166	220	298	133,4	162,1	133,4	229	211	227

Coupling Size**	Max. RPM		Max. Continuous Torque	Peak Overload Torque	Weight*	Weight Change Per mm of "C"	WR ² *	WR ² Change Per mm of "C"	Axial Capacity
	Not Balanced	Balanced	Nm	Nm	kg	kg	kgm ²	kgm ²	mm
150	9 000	20 800	105	210	3,0	0,0008	0,0031	0,00179	±0,127
175	8 300	17 000	184	368	4,3	0,001	0,0060	0,00288	±0,178
225	7 700	16 000	345	691	6,4	0,003	0,0123	0,00340	±0,191
300	6 800	14 000	820	1 639	11,8	0,008	0,0354	0,00465	±2,159
350	6 200	13 500	1 513	3 026	19,5	0,014	0,0758	0,00751	±2,296
375	5 650	12 000	2 179	4 358	25,0	0,019	0,01238	0,00769	±2,413
412	5 350	11 000	2 540	5 080	32,2	0,033	0,1799	0,01072	±2,794
462	5 000	10 000	4 561	9 122	45,9	0,054	0,3248	0,01430	±3,048
512	4 700	9 200	6 209	12 418	61,3	0,086	0,5355	0,01859	±3,302
562	4 350	8 300	9 494	18 988	84,4	0,120	0,8837	0,02288	±3,683
600	4 150	7 800	10 352	20 704	103,5	0,202	1,2436	0,03128	±4,064

* Weight (m) and inertia (WR²) calculated at minimum DBSE and maximum bore.

REXNORD THOMAS SR71-8

Disc Coupling



ATEX II 2GD c T5



THOMAS
SR71-8
SERIES

Reliable Performance. Trusted Brands.



Design Features include:

- Unitized and piloted center member allowing easy installation and repeatable balance
- Bolt on hubs for oversize bore capacity
- Unique jacking bolt feature compressing coupling for easy installation and removal of center member assembly

Tasarım Özellikleri şunları içerir:

- Birleştirilmiş ve pilot merkeze kolay izin veren kurulum ve tekrarlanabilir denge
- Büyük boy için göbeklerde civata delik kapasitesi
- Kaplini sıkıktırmak için benzersiz kriko civatası özelliği

Applications:

- Pumps
- Compressors
- Fans
- Paper Machines
- Synchronized rollers
- Wire Feeders
- Blowers

Industry Compliant:

- API 671/ISO 10441 (when specified)
- API 610/ISO 13709
- ISO 14691
- ATEX II 2GD c T5

Special design options:

- Torsionally adjusted
- Limited end float
- Torque meter
- Reduced sparking

Uygulamalar:

- Pompalar
- Kompresörler
- Hayranlar
- Kağıt Makineleri
- Senkronize silindirler
- Tel Besleyiciler
- Vantilatörler

Endüstri Uyumlu:





- API 671 / ISO 10441 (belirtildiğinde)
- API 610 / ISO 13709
- ISO 14691
- ATEX II 2GD c T5

Özel tasarım seçenekleri:

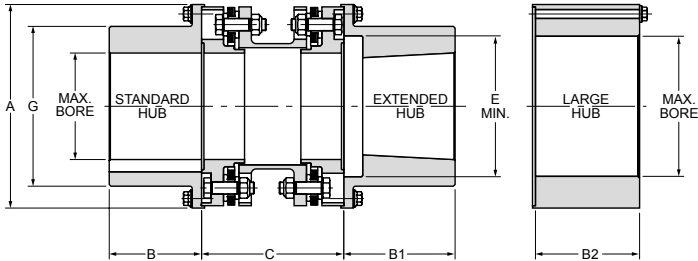
- Elektrik yalıtımlı
- Burulma ayarlı
- Sınırlı uç kayma
- Tork ölçer
- Daha az kıvılcım

REXNORD THOMAS SR71-8
DİSK KAPLINLER

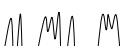

Torque Demands Driven Machine	Typical Application for Electric Motor or Turbine Driven Equipment	Typical Service Factor
	Constant torque such as centrifugal pumps blowers and compressors	1.0
	Continuous duty with some torque variations including plastic extruders and forced draft fans	1.5
	Light shock loads from metal extruders, cooling towers and log haulers	2.0
	Moderate shock loading as expected from a car dumper, stone crusher, vibrating screen	2.5
	Heavy shock load with some negative torques from reciprocating pumps, compressors, reversing turnout tables	3.0
	Frequent torque reversals such as reciprocating compressors with frequent torque reversals which do not necessarily include reverse rotations	Consult Rexnord Engineering

Standard "C" Dimensions B&B 1 Hub B2 Hub

Coupling Size**	Standard "C" Dimensions				B&B 1 Hub	B2 Hub	A	B	B1	B2	Min C	Max. E	G
	100	140	180	250	Max. Bore	Max. Bore							
	mm				mm								
225	•	•	•		80	100	152	63,5	79,2	77,7	121	106	116
262	•	•	•		95	112	175	77,7	93,7	90,4	140	119	132
312		•	•		112	140	203	90,4	109,5	104,6	152	146	160
350		•	•	•	130	155	227	98,6	120,7	114,3	171	165	179
375			•	•	144	176	252	112,8	134,9	131,1	184	181	202
425					158	189	273	124,0	149,4	139,7	191	189	214
450					170	205	294	128,5	157,2	152,4	222	213	236
500					196	241	333	150,9	179,3	171,5	260	232	267
550					215	Consult	373	166,6	198,4	Consult	292	254	292
600					242	Consult	416	182,6	214,4	Consult	318	298	336
700					248	Consult	471	211,1	246,1	Consult	368	325	373
750					275	Consult	511	227,1	261,9	Consult	400	363	413

TECHNICAL SPEC

Coupling Size	Max. RPM		Max. Continuous Torque	Peak Overload Torque	Weight*	Weight Change Per mm of "C"	WR ^{2*}	WR ² Change Per mm of "C"	Axial Capacity
	Not Balanced	Balanced	Nm	Nm	kg	kg	kgm ²	kgm ²	mm
225	7 500	14 000	1 976	3 951	12,6	0,00679	0,037	0,000012	0,91
262	6 800	12 500	3 706	7 413	19,5	0,00822	0,078	0,000022	1,09
312	6 200	11 500	5 803	11 605	30,4	0,00983	0,170	0,000038	1,29
350	5 700	10 500	7 552	15 105	43,1	0,01341	0,302	0,000065	1,42
375	5 200	9 800	11 323	22 646	60,8	0,01877	0,522	0,000106	1,57
425	5 000	9 300	15 161	30 323	76,7	0,02181	0,765	0,000145	1,70
450	4 700	8 700	16 979	33 958	99,9	0,02842	1,176	0,000207	1,82
500	4 200	7 900	27 817	55 633	154,8	0,03789	2,353	0,000362	2,02
550	3 900	7 300	37 300	74 599	215,7	0,04737	4,076	0,000574	2,33
600	3 600	6 800	48 973	97 945	296,5	0,05452	7,060	0,000796	2,59
700	3 300	6 200	76 180	152 359	436,3	0,07382	13,138	0,001359	2,92
750	3 100	5 800	94 694	189 388	563,9	0,09241	20,254	0,002016	3,17

* Weight (m) and inertia (WR²) calculated at minimum DBSE and maximum bore.

REXNORD THOMAS SR52

Disc Coupling



ATEX II 2GD c T5



THOMAS
SR52
SERIES

Reliable Performance. Trusted Brands.



Design Features include:

- Unitized disc packs allowing easy installation
- High torque to outer diameter ratio resulting in smaller coupling selection and higher speed potential

Tasarım Özellikleri şunları içerir:

- Birleştirilmiş disk paketleri ile kolay kurulum
- Dışa doğru yüksek tork çap oranı ile sonuçlanan daha küçük kaplin seçimi ve daha yüksek hız potansiyeli

Applications:

- Pumps
- Compressors
- Fans

Special design options:

- Electrically insulated
- Torsionally adjusted
- Limited end float
- Torque meter
- Reduced sparking

Uygulamalar:

- Pompalar
- Kompresörler
- Fanlar

Özel tasarım seçenekleri:

- Elektrik yalıtımlı
- Burulma ayarlı
- Sınırlı uç kayma
- Tork ölçer
- Daha az kıvılcım

Industry Compliant:





- ISO 14691
- ATEX II 2GD c T5

Endüstri Uyumlu:

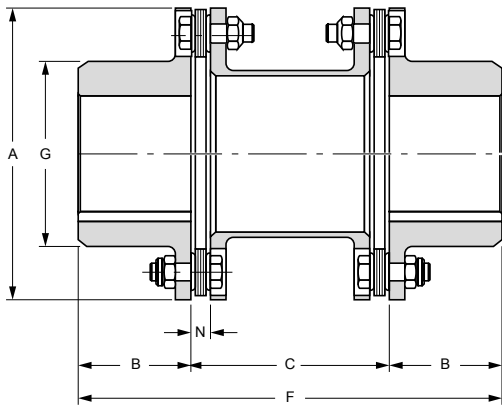
- ISO 14691
- ATEX II 2GD c T5

REXNORD THOMAS SR52
DİSK KAPLINLER

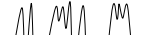

Torque Demands Driven Machine	Typical Application for Electric Motor or Turbine Driven Equipment	Typical Service Factor
	Constant torque such as centrifugal pumps blowers and compressors	1.0
	Continuous duty with some torque variations including plastic extruders and forced draft fans	1.5
	Light shock loads from metal extruders, cooling towers and log haulers	2.0
	Moderate shock loading as expected from a car dumper, stone crusher, vibrating screen	2.5
	Heavy shock load with some negative torques from reciprocating pumps, compressors, reversing turnout tables	3.0
	Frequent torque reversals such as reciprocating compressors with frequent torque reversals which do not necessarily include reverse rotations	Consult Rexnord Engineering

N Max. Max. Torque

Coupling Size**	Not Balanced	Balanced	Continuous Peak	Peak	Max. Bore	A	B	C min	C std.	F min	G	N	Weight*	Weight Change per mm of C	WR ^{2*}	WR ² Change per mm of C	Axial Capacity
	min-1		Nm		mm	mm	mm	mm	mm	mm	mm	mm	kg	kgm ²		mm	
	Standard C dimension see table below																
125	5000	15000	305	610	34	94	33	51,6		118	52	6,7	2,2	0,0028	0,002	0,002	0,91
162	4600	15000	604	1208	50	110	44	51,6		140	70	7,1	3,7	0,0037	0,005	0,003	0,91
200	4250	15000	1186	2371	58	138	52	66,8		171	83	9,1	6,6	0,0045	0,014	0,007	0,91
225	4100	14000	1976	3952	70	144	67	69,9		204	96	9,1	8,1	0,0047	0,02	0,008	0,91
262	3900	13000	3707	7414	84	168	73	81,8		228	114	11,9	13,6	0,0072	0,044	0,015	1,09
312	3450	11700	5804	11607	97	198	86	95,3		267	133	12,7	22,7	0,0087	0,102	0,027	1,3
350	3200	10500	7554	15107	110	221	95	105,7		296	146	13,5	31,5	0,0097	0,18	0,037	1,42
375	3000	9400	11325	22650	120	246	102	116,6		327	165	15,1	44,7	0,0133	0,31	0,061	1,57
425	2800	8700	15164	30327	130	267	108	125,5	250	341	178	15,9	57,5	0,0173	0,44	0,094	1,7
450	2700	8100	16982	33963	140	287	114	135,6	250	364	189	18,3	70,7	0,0184	0,66	0,111	1,83
500	2500	7100	27821	55642	146	327	127	153,2	250	407	213	19,8	102	0,0245	1,25	0,198	2,08
550	2300	6300	37305	74611	166	367	140	174,8	250	455	240	23	142	0,0387	2,23	0,382	2,34
600	2150	5700	48980	97960	176	406	152	190,5	250	495	260	24,6	186	0,0430	3,58	0,525	2,59
700	1950	5000	76191	152383	205	464	178	217,4	300	573	298	30,5	259	0,0714	4,82	1,04	2,92
750	1850	4600	98096	196191	224	503	191	235	300	617	321	32,3	327	0,0893	7,17	1,5	3,18
800	1750	4300	121795	243591	241	546	210	254,5	300	675	346	34	413	0,1071	10,8	2,3	3,45
850	1600	3900	143734	287467	250	584	222	273,1	350	717	368	35,6	503	0,1071	15	2,3	3,66
925	1500	3600	194656	389312	270	635	241	292,1	500	774	400	38,1	662	0,1429	23,3	4,61	3,96
1000	900	3250	220173	440347	300	699	267	368	500	902	438	42,9	853	0,1607	36	5,83	4,37
1100	800	3100	262514	525029	320	741	286	406	600	978	470	44,5	1021	0,1964	49,3	9,15	4,65
1200	650	2800	320098	640196	345	816	311	432	600	1054	514	50	1365	0,2679	78,8	13,74	5,16
1300	600	2600	382763	765526	380	876	337	457	700	1131	556	51,6	1660	0,2679	109,6	15,55	5,54

* Weight (m) and inertia (WR²) calculated at minimum DBSE and maximum bore.

Coupling Size**	100	140	180	250	300	400	3,5	4	5	5,5	6	7	8
	mm						inch						
125	•	•											
162	•	•	•						•				
200	•	•							•				
225	•	•	•	•					•				
262		•	•	•					•				
312		•	•	•									•
350			•	•							•		•
375			•	•								•	

REXNORD THOMAS SR54-RDG

Disc Coupling



ATEX II 2GD c T5



THOMAS
SR54-RDG
SERIES

Reliable Performance. Trusted Brands.



Design Features include:

- Easy installation and reduced maintenance costs with the axially split center member
- Stainless steel disc packs are supplied as standard
- High torque and speed capacity with the piloted split center spool

Tasarım Özellikleri şunları içerir:

- Eksenel bölünmüş merkez ile kolay kurulum ve azaltılmış bakım maliyetleri
- Paslanmaz çelik disk paketleri standart olarak verilir
- Bölünmüş merkez biriktirme ile Yüksek tork ve hız pilotlu kapasite..

Applications:

- Pumps
- Compressors
- Conveyors
- Paper machines
- Pulpers
- Mill drives

Industry Compliant:

- API 610/ISO 13709
- ISO 14691
- ATEX II 2G c T5

Uygulamalar:





- Pompalar
- Kompresörler
- Konveyörler
- Kağıt makineleri
- Pulpers
- Freze sürücülere

Endüstri Uyumlu:

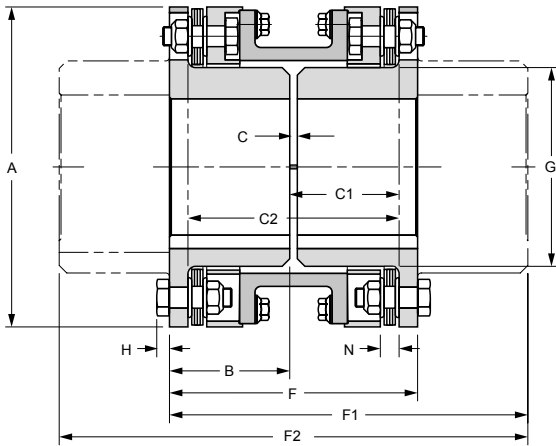
- API 610 / ISO 13709
- ISO 14691
- ATEX II 2G c T5

REXNORD THOMAS SR54-RDG
DİSK KAPLINLER

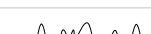

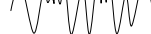
Torque Demands Driven Machine	Typical Application for Electric Motor or Turbine Driven Equipment	Typical Service Factor
	Constant torque such as centrifugal pumps blowers and compressors	1.0
	Continuous duty with some torque variations including plastic extruders and forced draft fans	1.5
	Light shock loads from metal extruders, cooling towers and log haulers	2.0
	Moderate shock loading as expected from a car dumper, stone crusher, vibrating screen	2.5
	Heavy shock load with some negative torques from reciprocating pumps, compressors, reversing turnout tables	3.0
	Frequent torque reversals such as reciprocating compressors with frequent torque reversals which do not necessarily include reverse rotations	Consult Rexnord Engineering

TECHNICAL SPEC

Coupling Size**	Max. Bore Internal	A	B	C	C1**	F	F1	H	N	G	C2**	F2***
		mm	mm	mm	mm	mm	mm	mm	mm	mm	mm	mm
125	30	97	48	3,0	44,5	99	125	4,3	6,9	44	85,9	152,4
162	42	114	48	3,0	45,0	99	137	4,3	7,4	59	86,9	175,8
200	58	141	54	3,0	49,8	111	156	5,6	9,1	83	96,5	201,2
225	65	149	56	3,0	51,6	114	174	5,6	9,1	89	100,1	233,2
262	74	175	66	4,8	61,5	136	200	6,4	11,9	105	118,1	264,4
312	95	199	72	4,8	66,5	149	225	7,6	12,7	127	128,3	300,0
350	100	223	83	6,4	77,7	173	256	8,6	13,7	140	149,1	339,6
375	114	247	90	6,4	82,8	187	275	9,9	15,0	154	159,3	362,5
425	120	267	101	6,4	91,7	208	300	10,7	15,7	167	177,0	392,9
450	130	287	114	7,9	105,4	236	334	11,9	18,0	178	202,9	431,5
500	137	327	121	7,9	109,7	251	358	12,7	19,8	200	211,6	465,6
550	150	367	136	9,7	123,7	282	400	14,7	23,1	222	237,7	517,1
600	166	406	152	9,7	137,2	314	442	17,0	24,9	236	264,7	569,5
700	195	464	178	9,7	158,0	365	514	19,1	30,5	276	306,3	661,9

** One internal and one external hub. / *** Two external hubs.

Coupling Size	Max. RPM (1)		Max. Continuous Torque	Peak Overload Torque	m (2)	J (2)	Axial Capacity
	Not Balanced	Balanced					
125	4 600	10 500	305	610	3,1	0,004	±0,91
162	4 200	9 700	604	1 208	4,2	0,007	±0,91
200	3 800	8 600	1 185	2 371	7,3	0,020	±0,91
225	3 700	8 400	1 976	3 951	8,6	0,025	±0,91
262	3 600	7 400	3 706	7 413	14,1	0,056	±1,09
312	3 000	6 700	5 803	11 605	20,9	0,112	±1,29
350	2 800	6 200	7 552	15 105	30,0	0,202	±1,42
375	2 500	4 800	11 323	22 646	40,0	0,339	±1,57
425	2 300	5 400	15 161	30 323	53,1	0,521	±1,70
450	2 200	5 000	16 979	33 958	69,9	0,787	±1,82
500	2 000	4 600	27 817	55 633	101,7	1,454	±2,02
550	1 900	4 200	37 300	74 599	147,1	2,625	±2,33
600	1 800	3 900	48 973	97 945	198,4	4,360	±2,59
700	1 700	3 600	76 180	152 359	298,3	8,485	±2,92

Larger sizes to 194.600 Nm MCT available upon request.

(1) Contact Rexnord for explanation of RPM limits and balancing recommendations. / (2) Weight (m) and Inertia (J) with standard length hubs, maximum bore and standard C.

REXNORD THOMAS AMR-CMR

Disc Coupling



ATEX II 2GD c T5



THOMAS
AMR-CMR
SERIES

Reliable Performance. Trusted Brands.



Design Features include:

- Unitized disc pack (T-Pack) for easy installation
- Robust and economical design with the cast* hubs and center member
- Open lug type center member for reciprocating applications
- Flywheel adapter plate bolts directly to the flywheel of an engine or compressor

Tasarım Özellikleri şunları içerir:

- Kolay kurulum için birleştirilmiş disk paketi (T-Pack)
- Döküm göbeklerle sağlam ve ekonomik tasarım
- Açık pabuç tipi merkez karşılıklı üye uygulamaları
- Volan adaptör plakası doğrudan bir motorun veya kompresörün volnuna bağlanması

Applications:

- Compressors
- Mill drives
- Conveyors
- Crushers
- Generators
- Diesel engine drives

Special design options:

- Mechanical clamping hubs
- SAE and special flange adapters
- Hydraulic shaft-hub connections

Industry Compliant:

- ATEX II 2GD c T5

Uygulamalar:

- Pompalar
- Kompresörler
- Fanlar

Endüstri Uyumlu:





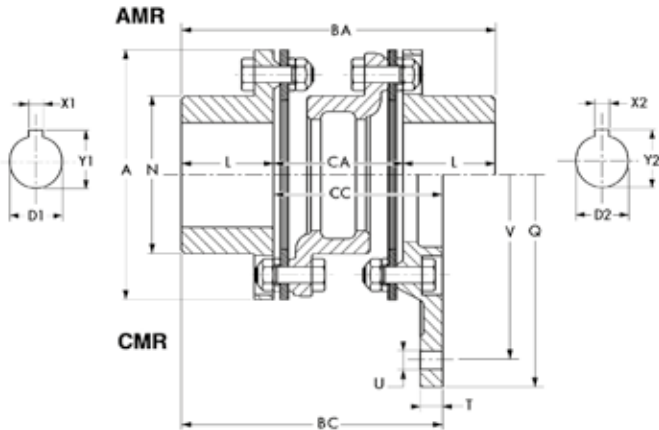

- ATEX II 2GD c T5

Özel tasarım seçenekleri:

- Mekanik sıkıştırma göbekleri
- SAE ve özel flanş adaptörler
- Hidrolik mil-göbek bağlantıları

REXNORD THOMAS AMR-CMR
DİSK KAPLILAR



Torque Demands Driven Machine	Typical Application for Electric Motor or Turbine Driven Equipment	Typical Service Factor
	Constant torque such as centrifugal pumps blowers and compressors	1.0
	Continuous duty with some torque variations including plastic extruders and forced draft fans	1.5
	Light shock loads from metal extruders, cooling towers and log haulers	2.0
	Moderate shock loading as expected from a car dumper, stone crusher, vibrating screen	2.5
	Heavy shock load with some negative torques from reciprocating pumps, compressors, reversing turnout tables	3.0
	Frequent torque reversals such as reciprocating compressors with frequent torque reversals which do not necessarily include reverse rotations	Consult Rexnord Engineering

TECHNICAL SPEC

Coupling Size**	Max. Continuous Torque	n _{max}	D1		A	BA	BC	CA	CC	L	N	Q	T	J	J	m	m
			D2	D2										AMR	CMR	AMR	CMR
			min	max										kgm ² (**)		kg (**)	
162	648	2 500	0	50	117	156	129	66,7	84,1	44	70	159	7,9	0,006	0,008	4,0	3,6
200	1 245	2 500	0	60	146	184	152	76,2	98,4	54	92	187	9,5	0,016	0,020	6,4	5,4
225	1 758	2 500	0	70	152	203	162	76,2	98,4	64	98	194	9,5	0,021	0,038	8,5	7,3
262	2 375	2 500	0	85	175	235	186	88,9	113,7	73	114	216	11,1	0,043	0,055	12,5	11,8
312	2 670	2 500	0	95	206	276	221	104,8	134,9	86	138	241	12,7	0,108	0,114	22,0	18,1
350	5 961	2 300	0	110	232	306	244	115,9	149,2	95	152	276	12,7	0,183	0,184	30,5	25,4
375	8 968	2 200	0	120	256	333	270	130,2	168,3	102	165	302	14,3	0,299	0,304	41,5	34,9
425	9 935	2 000	0	130	280	357	289	141,3	181,0	108	178	333	15,9	0,468	0,521	53,5	45,8
450	15 367	1 900	0	140	302	379	308	150,8	193,7	114	189	375	17,5	0,626	0,723	64,4	57,2
500	22 663	1 800	68	145	341	427	349	173,0	222,2	127	213	406	19,1	1,24	1,393	91,6	81,6
550	31 052	1 800	68	166	381	475	391	185,3	250,8	140	240	457	22,2	2,02	2,253	126	111
600	40 514	1 800	94	170	425	519	429	214,3	276,3	152	262	467	25,4	3,22	3,599	170	150
700	51 535	1 500	108	175	481	600	494	244,5	315,9	178	298	518	25,4	6,29	6,818	260	227
750	72 808	1 500	125	190	524	635	527	266,7	342,9	184	321	610	28,6	9,45	10,036	310	277
800	91 869	1 200	132	200	568	683	572	288,9	374,7	197	349	651	31,8	17,15	17,176	405	363
850	101 456	1 100	138	215	603	727	610	308,0	400,0	210	368	695	31,8	20,25	21,448	500	442
925	144 647	1 000	151	235	654	794	667	336,6	438,2	229	403	734	34,9	31	31,31	630	535
1000	167 894	900	165	254	718	851	713	368,0	471,0	241	445	803	41,1	52	47	855	743
1100	230 978	800	178	279	768	914	764	394,0	503,0	260	470	848	44,5	74	75	1026	878
1200	248 612	650	191	305	848	992	827	433,0	548,0	279	514	953	50,8	120	124	1346	1148
1300	269 475	600	203	330	914	1075	897	465,0	592,0	305	572	1013	53,8	171	172	1755	1 494
1550	352 676	600	216	394	997	1230	972	494,0	603,0	368	660	1108	53,8	270	255	2318	1 845

* Maximum bores for keyways as per ISO R773

** Weight (m) and inertia (J) for maximum bore and minimum adapter diameter

REXNORD addax

Composite Coupling



ATEX II 2GD c T5



Reliable Performance. Trusted Brands.

Unitized high strength composite flex element

316 stainless steel hubs and hardware



Composite center section with patented integral coupling flange

Design Features include:

- Corrosion-resistant center member, flex element, hub and hardware lowering the cost of ownership and extending service life
- Low weight allowing easy installation
- High strength to weight ratio providing reduced vibration
- Low coefficient of thermal expansion giving dimensional stability and reduced stresses
- Continuous fiber composite spacer flange resulting in infinite fatigue life and low cost of ownership
- Unitized flex element and high misalignment capacity for reduced maintenance

Tasarım Özellikleri şunları içerir:

- Korozyona dayanıklı merkez üye, esnek eleman, göbek ve donanım maliyeti indirme, hizmet ömrünün uzatılması
- Kolaylık sağlayan düşük ağırlık kurulum
- Ağırlığa karşı yüksek mukavemet oran sağlayan indirgenmiş titreşim
- Düşük katsayısı termal genleşme veren boyutsal kararlılık ve azaltılmış stresler
- Sürekli fiber kompozit ara flanş sonucu sonsuz yorgunluk ömrü ve düşük mülkiyet maliyeti
- Birleştirilmiş esnek eleman ve yüksek yanlış hizalama kapasitesi daha az bakım için

Applications:

- Cooling towers
- Vertical pumps

Special design options:

- Brake disc
- Backstop
- Electrically insulated

Uygulamalar:

- Soğutma kuleleri
- Dikey pompalar

Özel tasarım seçenekleri:

- Fren diskli
- Geri döndürmez kilit
- Elektrik yalıtımlı

Industry Compliant:

- ISO 14691
- ATEX II 2G c T5

Endüstri Uyumlu:

- ISO 14691
- ATEX II 2G c T5

REXNORD ADDAX

KOMPOZİT KAPLINLER

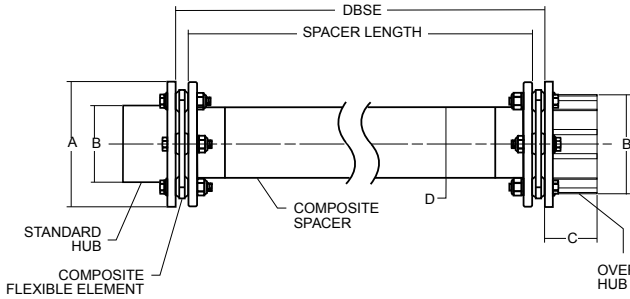

Models: 350.275, 375.275, 450.275, 485.338, 650.425, 850.625

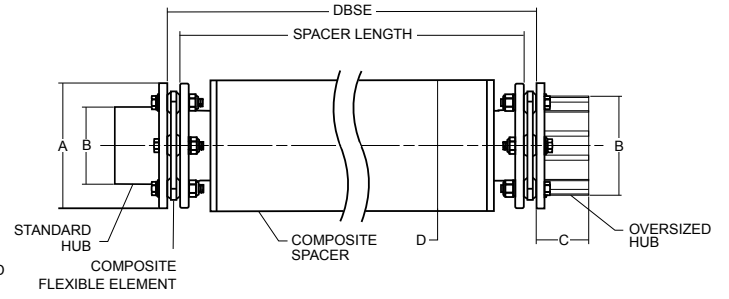

Models: 485.425, 650.625, 650.825, 850.825, 850.1025, 850.1275

TECHNICAL SPEC

Max. Bore

B

C

Model Series	Spacer & Flange Material	Max. DBSE @ 1780 RPM @ 1.15SF	Max. DBSE @ 1480 RPM @ 1.15SF	Standard		A	Standard		Standard		D	Min. DBSE	Min. Bore
				(in)	(mm)		(in)	(mm)	(in)	(mm)			
350.275	LRF	(95) / 2 413	(106) / 2 692	(2,13)	(2,38)	(5,25)	(3,06)	(4)	(1,81)	(2,6)	(2,75)	(5,4)	(0,63)
	LRA	(107) / 2 718	(119) / 3 023	55	65	133	78	102	46	66	70	137	16
	LRR	(114) / 2 896	(126) / 3 200										
375.275	LRF	(95) / 2 413	(106) / 2 692	(2,13)	(2,38)	(5,25)	(3,06)	(4)	(1,81)	(2,6)	(2,75)	(5,4)	(0,63)
	LRA	(107) / 2 718	(119) / 3 023	55	65	133	78	102	46	66	70	137	16
	LRR	(114) / 2 896	(126) / 3 200										
450.275	LRF	(95) / 2 413	(106) / 2 692	(2,25)	(2,88)	(5,25)	(3,15)	(4)	(1,81)	(2,63)	(2,75)	(5,4)	(0,63)
	LRA	(107) / 2 718	(119) / 3 023	55	75	133	80	102	46	67	70	137	16
	LRR	(114) / 2 896	(126) / 3 200										
485.338	LRX	(128) / 3 251	(141) / 3 581										
	LRF	(100) / 2 540	(113) / 2 870	(2,63)	(3,38)	(6,00)	(3,72)	(4,75)	(2,5)	(2,75)	(3,38)	(8,0)	(0,87)
	LRA	(116) / 2 946	(127) / 3 226	70	85	152	94	121	63,5	70	86	203	22
485.425	LRR	(141) / 3 581	(154) / 3 912	(2,63)	(3,38)	(6,00)	(3,72)	(4,75)	(2,5)	(2,75)	(4,25)	(8,0)	(0,87)
	LRX	(154) / 3 912	(169) / 4 293	70	85	152	94	121	63,5	70	108	203	22
485.625	LRR	(170) / 4 318	(189) / 4 800	(2,63)	(3,38)	(6,00)	(3,72)	(4,75)	(2,5)	(2,75)	(6,25)	(9,5)	(0,87)
650.425	LRA	(133) / 3 378	(148) / 3 759	(3,13)	(4,01)	(6,75)	(4,25)	(5,15)	(2,56)	(2,75)	(4,25)	(6)	(1,00)
	LRR	(141) / 3 581	(154) / 3 912	80	100	171	108	133	65	70	108	152	25
	LRX	(154) / 3 912	(169) / 4 293										
650.625	LRR	(170) / 4 318	(189) / 4 800	(3,13)	(4,01)	(6,75)	(4,25)	(5,15)	(2,56)	(2,75)	(6,25)	(9,5)	(1,00)
	LRX	(186) / 4 725	(208) / 5 283	80	100	171	108	133	65	70	159	241	25
650.825	LRR	(193) / 4 902	(215) / 5 461	(3,13)	(4,01)	(6,75)	(4,25)	(5,15)	(2,56)	(2,75)	(8,25)	(9,5)	(1,00)
	LRX	(209) / 5 309	(232) / 5 893	80	100	171	108	133	65	70	210	241	25
850.625	LRA	(157) / 3 988	(172) / 4 369	std. short	(5,06)	(9,0)	(5,8)	(7,5)	std. short	(3,5)	(6,25)	(14,2)	(1,00)
	LRR	(170) / 4 318	(189) / 4 800	(3,125) / 75	130	229	147	191	(2,5) / 63,5	89	159	361	25
	LRX	(186) / 4 725	(208) / 5 283	std. Long					(3,31) / 84,1				
850.825	LRR	(193) / 4 902	(215) / 5 461	std. short	(5,06)	(9,0)	(5,8)	(7,5)	std. short	(3,5)	(8,25)	(14,2)	(1,00)
	LRX	(209) / 5 309	(232) / 5 893	(3,125) / 75	130	229	147	191	(2,5) / 63,5	89	210	361	25
850.1025	LRR	(193) / 4 902	(215) / 5 461	std. Long					(3,31) / 84,1				
	LRX	(229) / 5 817	(253) / 6 426	(4,13) / 105									
850.1275	LRR	(193) / 4 902	(215) / 5 461	std. short	(5,06)	(9,0)	(5,8)	(7,5)	std. short	(3,5)	(12,75)	(14,2)	(1,00)
	LRX	(245) / 6 223	(275) / 6 985	(3,125) / 75	130	229	147	191	(2,5) / 63,5	89	324	361	25

LRF = Fiberglass

LRA = Amalgamation (carbin fiber & fiberglass)

LRR = Standard carbon fiber

LRX = Special carbon fiber

REXNORD **addax**

Composite Coupling / Kompozit Kaplinler



Torque Demands Driven Machine	Typical Application for Electric Motor or Turbine Driven Equipment	Typical Service Factor
	Constant torque such as centrifugal pumps blowers and compressors	1.0
	Continuous duty with some torque variations including plastic extruders and forced draft fans	1.5
	Light shock loads from metal extruders, cooling towers and log haulers	2.0
	Moderate shock loading as expected from a car dumper, stone crusher, vibrating screen	2.5
	Heavy shock load with some negative torques from reciprocating pumps, compressors, reversing turnout tables	3.0
	Frequent torque reversals such as reciprocating compressors with frequent torque reversals which do not necessarily include reverse rotations	Consult Rexnord Engineering

TECHNICAL SPEC

Model Series	Spacer & Flange Material	Continuous Torque @ 1.0 SF	Peak Overload Torque	Weight @ Min	WR ² @ Min DBSE	Weight change per length		WR ² change per length	
						(in-lb) / Nm	(lbs) / kg	(lb-in ²) / kgm ²	(lb/in) / kg/m
350.275	LRF	(3 617) / 408	(5 425) / 613	(13,8) / 6,2	(32) / 0,0093	(0,07) / 1,5		(0,13) / 0,0015	
	LRA					(0,06) / 1,2		(0,11) / 0,0013	
	LRR					(0,06) / 1,1		(0,10) / 0,0012	
375.275	LRF	(5 311) / 600	(7 967) / 900	(13,8) / 6,2	(32) / 0,0093	(0,07) / 1,5		(0,13) / 0,0015	
	LRA					(0,06) / 1,2		(0,11) / 0,0013	
	LRR					(0,06) / 1,1		(0,10) / 0,0012	
450.275	LRF	(7 250) / 820	(10 875) / 1 229	(12,9) / 5,9	(32) / 0,0093	(0,07) / 1,5		(0,13) / 0,0015	
	LRA					(0,06) / 1,2		(0,11) / 0,0013	
	LRR					(0,06) / 1,1		(0,10) / 0,0012	
	LRX					(0,06) / 1,2		(0,10) / 0,0012	
485.338	LRF	(11 000) / 1 243	(16 500) / 1 864	(23,4) / 10,6	(47) / 0,014	(0,09) / 1,8		(0,24) / 0,0029	
	LRA					(0,08) / 1,5		(0,21) / 0,0024	
	LRR					(0,07) / 1,4		(0,19) / 0,0022	
485.425	LRR	(11 000) / 1 243	(16 500) / 1 864	(24,0) / 10,9	(74) / 0,022	(0,09) / 1,7		(0,38) / 0,0044	
	LRX					(0,09) / 1,8		(0,39) / 0,0045	
485.625	LRR	(11 000) / 1 243	(16 500) / 1 864	(26,5) / 12,0	(92) / 0,027	(0,13) / 2,6		(1,2) / 0,015	
650.425	LRA	(18 275) / 2 065	(27 415) / 3 097	(31,5) / 14,3	(122) / 0,036	(0,10) / 1,9		(0,42) / 0,0049	
	LRR					(0,089) / 1,7		(0,38) / 0,0044	
	LRX					(0,092) / 1,8		(0,39) / 0,005	
650.625	LRR	(18 275) / 2 065	(27 415) / 3 097	(34,4) / 15,6	(141) / 0,041	(0,13) / 2,6		(1,2) / 0,014	
	LRX					(0,14) / 2,7		(1,3) / 0,015	
650.825	LRR	(18 275) / 2 065	(27 415) / 3 097	(37,9) / 17,2	(194) / 0,056	(0,18) / 3,4		(2,9) / 0,033	
	LRX					(0,18) / 3,6		(3,0) / 0,035	
850.625	LRA	(36 200) / 4 090	(54 300) / 6 135	(63,6) / 28,8	(440) / 0,130	(0,15) / 2,9		(1,4) / 0,016	
	LRR					(0,13) / 2,6		(1,2) / 0,014	
	LRX					(0,14) / 2,7		(1,3) / 0,015	
850.825	LRR	(36 200) / 4 090	(54 300) / 6 135	(68,5) / 31,0	(512) / 0,15	(0,18) / 3,4		(2,9) / 0,033	
	LRX					(0,18) / 3,6		(3,0) / 0,035	
850.1025	LRX	(36 200) / 4 090	(54 300) / 6 135	(74,8) / 33,9	(657) / 0,19	(0,23) / 4,4		(5,8) / 0,067	
850.1275	LRX	(36 200) / 4 090	(54 300) / 6 135	(78,4) / 35,6	(768) / 0,22	(0,28) / 5,5		(11,3) / 0,13	

The standard weight and inertia (WR²) values are at minimum DBSE and standard minimum bore for a complete assembly. To determine the total weight or inertia subtract the minimum DBSE from the total DBSE required and multiply that value times the WT and/or WR² change per length then add that calculated WT or WR² to the minimum DBSE values. Values may vary slightly depending on your actual bore and key size.



Ürün Bilgilerine Ulaşmak
İçin Akıllı Cihazınızla
Barkodu Okutun

REXNORD



KAPLINLERDE GÜVENİLİR
PERFORMANS

Reliable Performance in
COUPLINGS



DAL ELEKTRİK MOTORLARI VE GÜÇ AKTARIM SİS. SAN. TİC. A.Ş

Adnan Kahveci Bulvarı Haydar Akın İş Merkezi
2. Blok No: 208 / Kat:1 D:12 Şirinevler, İstanbul / TURKEY

Tel: +90(212) 451 5605 / Faks: +90(212) 451 5606 / e-mail: dalmotors@dal-group.com

www.dal.com.tr